

PRODUCT DATA SHEET

Douche Handset

Product Code: DOUCHE001

Product Name	DOUCHE001
Product Description	Douche Handset , Flexi and Holder
Product Transportation	
Barcode	5060500640217
Contry of origin	CH
Comodity code	8481801190
Product Measurements	
Product Weight (KG)	0.55
Product Width (mm)	46
Product Height (mm)	120.5
Product Depth (mm)	50.5
Product Length (mm)	1500
Primary Packed Measurements	
Packaged Weight	0.62
Packed Length	250
Packed Width	130
Packed Height	65
Packaging Weights	
Card (kg)	0.035
Paper (kg)	0
Wood (kg)	0
Plastic (kg)	0
Compliance DOP	HBDOC007 , HBDOC008

General Information	
Construction Material	Stainless Steel
Installation type	Wall Mounted
Colour / Finish	Chrome
Tap / Shower Attributes	
WRAS Approved	No
TMV Approved	No
Minimum Operating Pressure (bar)	0.5
Maximum Operating Pressure (bar)	5
Flexible Tails Included	No
Number of tap holes required	0
Handle Type	Gun
Swivel Spout	No
Inlet Connection	1/2 BSP
Outlet Connection	N/a
Tap Hole Diameter (mm)	N/a
Tap Type description	Douche
Includes Waste	No
Valve / Cartridge Type	N/a
Cartridge Spare code	N/a
Flow Rates	
0.2bar (l/min)	0
0.5bar (l/min)	0
1bar (l/min)	0
2bar (l/min)	0
3bar (l/min)	0



SCUDO
BEAUTIFUL BATHROOMS

0330 124 7290

sales@scudo.co.uk - www.scudo.co.uk

Scudo is the trading name of Harrison Bathrooms Ltd. Whilst we endeavour to ensure that the product information is accurate we accept no liability for any information given. All images are for illustration purposes only. Product images and specification are subject to change. Measurement are in millimetres and are nominal.

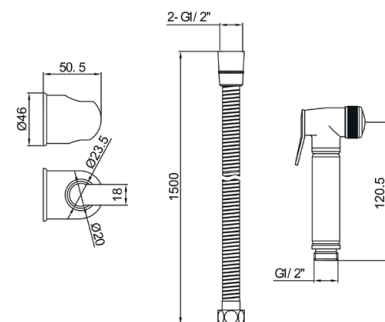

Dimensions

(measurements in mm)



LIFETIME GUARANTEE

We are confident in our products and we want our customer to be, we proudly give a lifetime guarantee on our taps and showers, further details can be found on our website