

We would like to thank you for purchasing our K^oGE tap.

Contents

Important Notices	3
Installation Requirements	4
Parts List	5
Installation Diagram	6
Installation Instructions	7
Boiling Water Tank Instructions	9
Troubleshooting	10
Specifications	11

Introduction

Please ensure this guide and instructions is fully read and understood prior to installation or operation of the product.

It is assumed due to the installation requirements; and risk of injury should the product be installed incorrectly. Installation is completed by a qualified competent person.

Intended Use

The Koge boiling water system, comprising the tap, boiling unit, and filter, is intended for indoor use only. This system is designed to provide instant boiling water for various domestic applications.

Important Notice

This product uses a submerged element to heat the water. The product must not be plugged in until the tank is full of water. Operating dry will cause the element to burn out instantly.

Make sure all electrical connections must with building regulations.

Make sure all water connections comply with building regulations.

Compatibility & Warranty

To ensure safety and warranty coverage, it is imperative that all components of this hot water system is provided by Koge from Scudo. Mixing products from other suppliers pose a potential safety hazard and will void the warranty.

Environmental Conditions

The system boiling unit should be placed in an environment with low humidity levels. All precautions should be taken to prevent exposure to freezing temperatures. This will prevent damage to the components and effect functionality. Environmental temperatures above 35°C may cause the product to overheat.

Boiler Unit Positioning

The unit must be placed upright on a flat surface; the unit must not be covered to allow adequate ventilation. Any deviation from this may result in operational issues and could compromise safety.

The boiler unit is not serviceable, do not attempt to open the casing or tamper with the power supply cable, in the event of a fault.

Filter Maintenance

To ensure the quality and safety of the dispensed water, the filter provided with the system must always be used and replaced at least every 6 months. Failure to do so may affect water quality and void the warranty. Only Koge replacement filters supplied directly from Scudo will maintain the product warranty (proof of purchase will be required).

Replacement Filters can be purchased here:
www.scudo.co.uk/spares

Open Vent

This product uses an open vent pipe to elevate pressure during the boiling process, it is important all means necessary to prevent the ventilation pipe from being blocked, twisted or kinked.



Replacement Filters

Installation Requirements

Electrical Requirements

A standard 220/240v 50Hz earthed 13amp switched electrical socket is required. This must be placed within reach of the boiler unit 13amp plug. Cable length is 110cm. Extension cables should not be used.

Please ensure that the circuit has available capacity for the 1.5kw power requirement. We recommend contacting a qualified electrician prior to installation. Failure to check may result in circuit overload, tripping of the RCD, or other electrical hazards.

The boiling unit is supplied with a moulded plastic plug and lead, ensure that this is not cut or tampered with.

Under no circumstance should the boiler casing be removed contact the supplier.

Do not under any circumstance plug in the appliance unless the system is fully primed with water.

Water Supply Requirements

Incoming hot and cold-water feeds should be installed with local accessible isolation close to the boiler unit. Warning do not include additional isolation to boiling unit beyond the inlet connection, this risks unintentional pressurisation.

It is recommended to fully flush the plumbing system prior to installation of the boiling water system, debris left might affect product function.

Ventilation Requirements

To avoid overheating or damaging electronic components, a zone of 10-15cm around the boiling unit is required around 3 sides of the unit. Humidity should not be above 60%, above this risks condensation which may affect electronic components.

Temperature Requirements

The product should only be used in an indoor environment. All preventative action should be taken to sure the product is not subject to ambient temperatures below 0°C or above 35°C. Should this be unavoidable the product should be electrically isolated, and the tank emptied.

Altitude Adjustment

Please note the product should never be allowed to reach boiling point, i.e. 100°C at sea level. Installations at higher elevations should take potential changes to the boiling point and adjust the maximum temperature to a minimum of 2°C below.

Prolonged Inactivity

Should the product be subject to prolonged periods of no use it is recommended to turn the boiler unit off, isolate the power supply and drain the tank.

Flow Rate	½ Bar	1 Bar	1½ Bar	2 Bar	3 Bar
Cold Water	4.0L	5.8L	7.0L	8.2L	10.2L
Hot Water	4.0L	5.8L	7.0L	8.2L	10.2L
Mixer Water	5.4L	7.7L	9.2L	10.8L	13.1L
Boiling Water	0.8L	0.9L	1.3L	1.5L	1.8L

N°	Description	QTY
A	Tap	1
B	O-Ring	1
C	Rubber Washer	1
D	Metal Washer	1
E	Mounting Nut	1
1	Cold Flexible Hose	1
2	Hot Flexible Hose	1
3	Hose from Filter Outlet to Tap	1
4	Hose from Tap to Boiler Unit	1
5	Hose from Boiler Unit to Tap	1
6	Hose from Cold Outlet to Filter Inlet	1
7	Flex Hose Adapter ($\frac{3}{8}$ to $\frac{1}{2}$ thread)	2

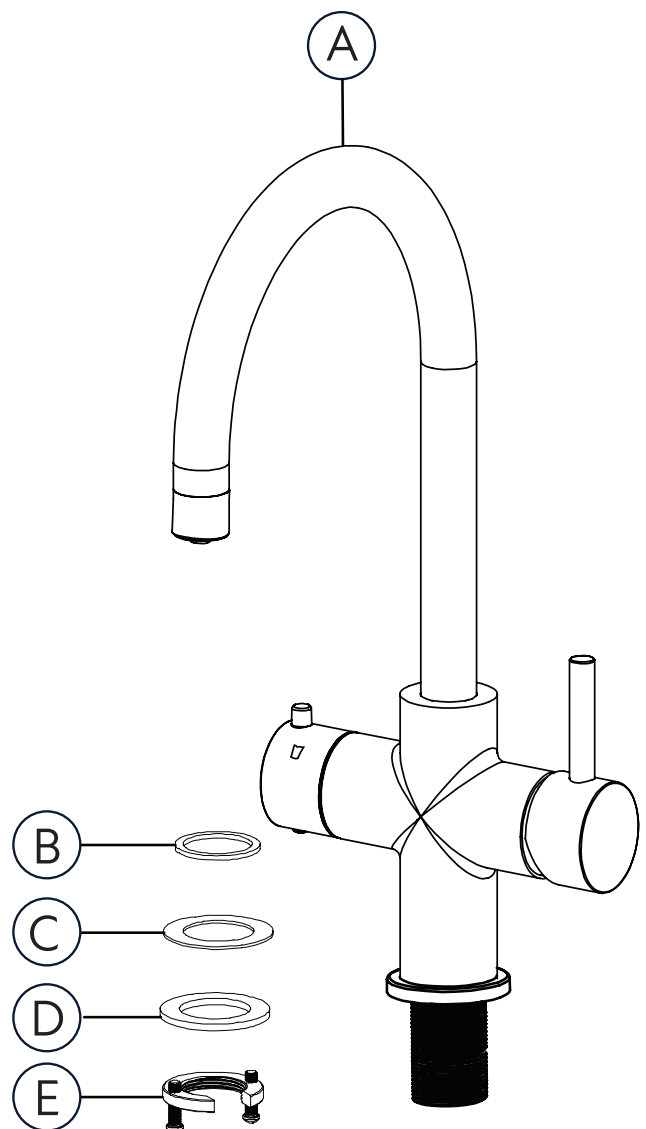
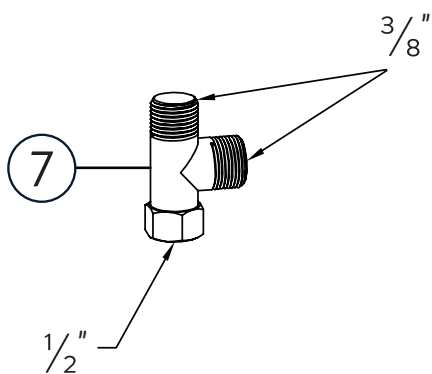

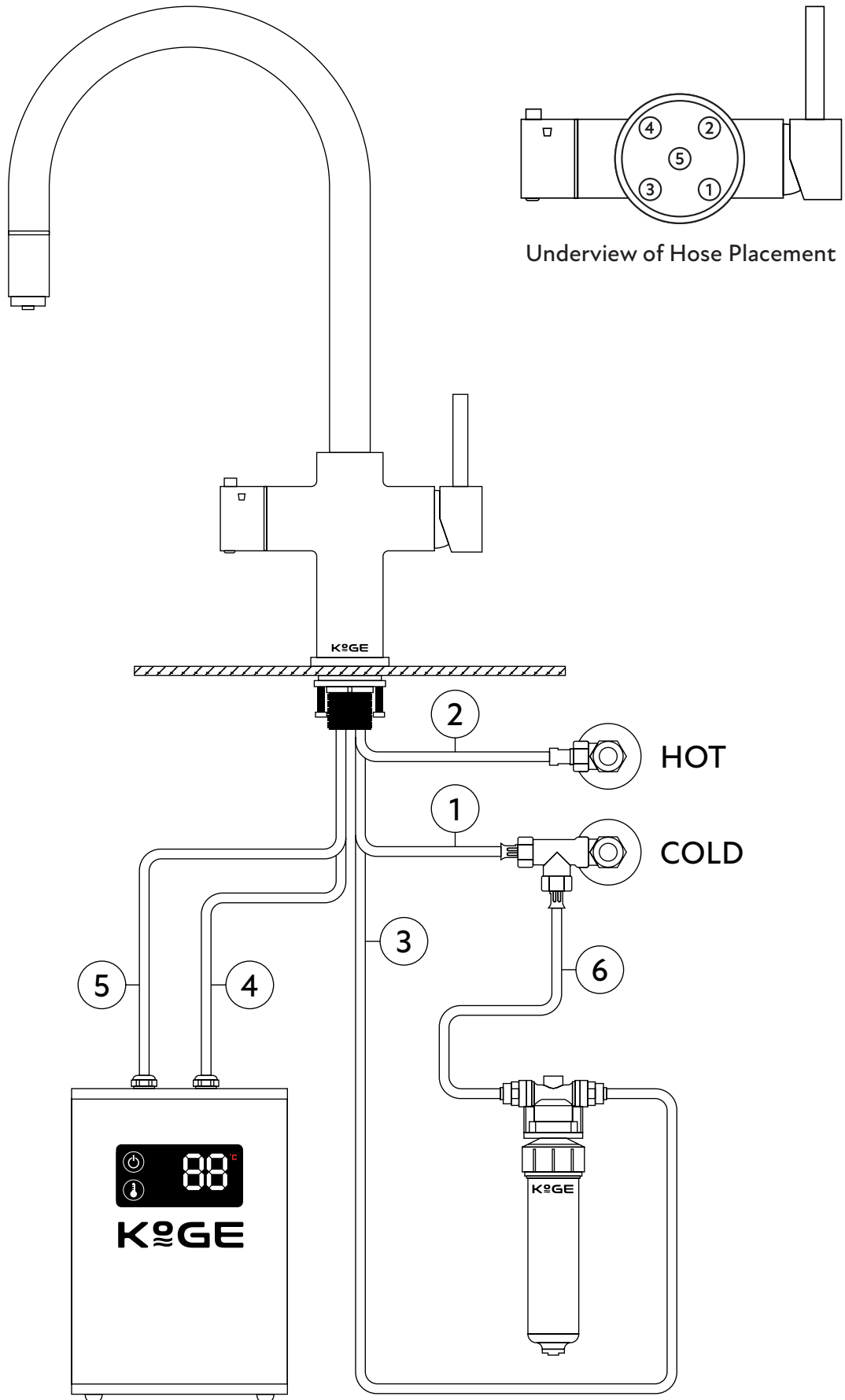

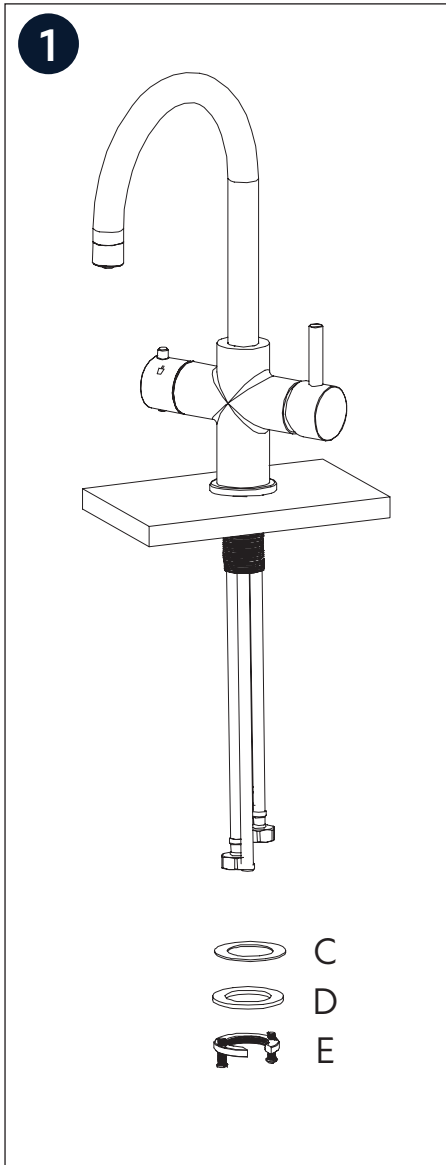

Slide the Rubbergasket (C) first, Metalwasher (D) second, then the mounting nut (E) over the hoses onto the stem.

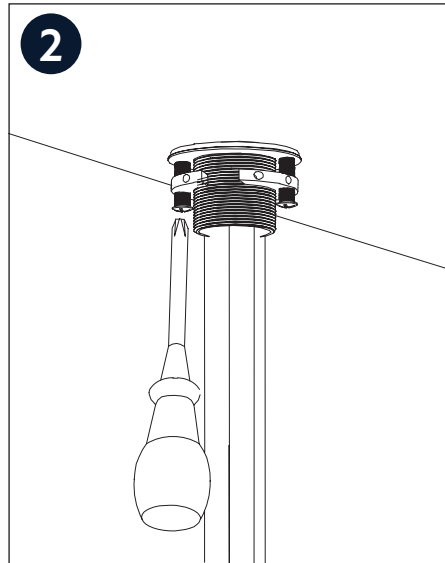

Use a Phillips head screwdriver to thread the 2 screws.

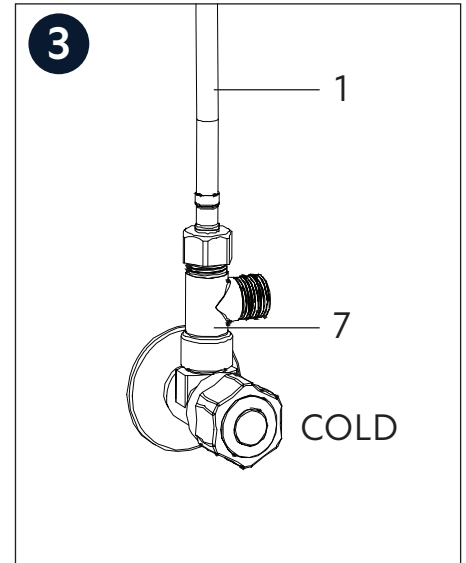

Connect the Cold flexible hose (1) & T Adapter (7) onto the cold matching water valves and secure the connection with a spanner.

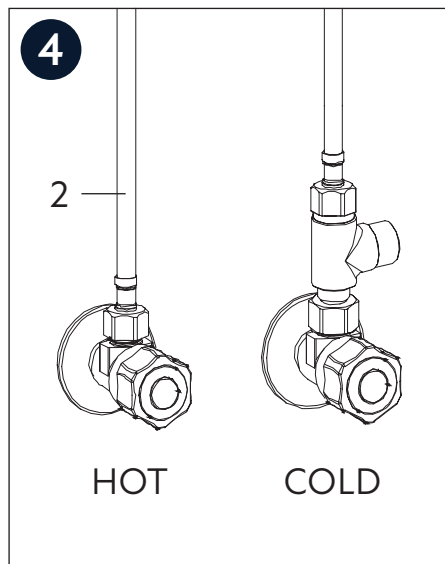

Connect the Hot flexible hose (2) onto the hot matching water valve, and secure the connection with a spanner.

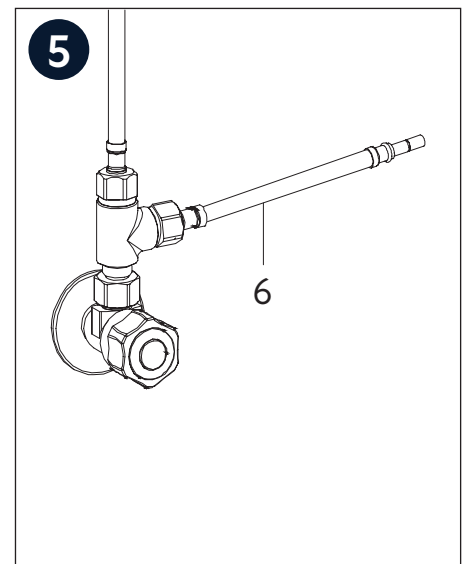

Connect hose (6) onto the other end of T Adaptor (7), and the other end of the hose fitted onto the filter inlet. Then secure the connection.

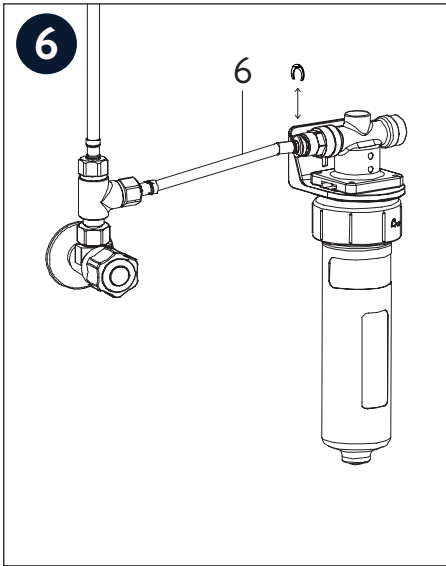

Before inserting the hose into filter inlet, remove the blue tab and replace once the hose is connected.

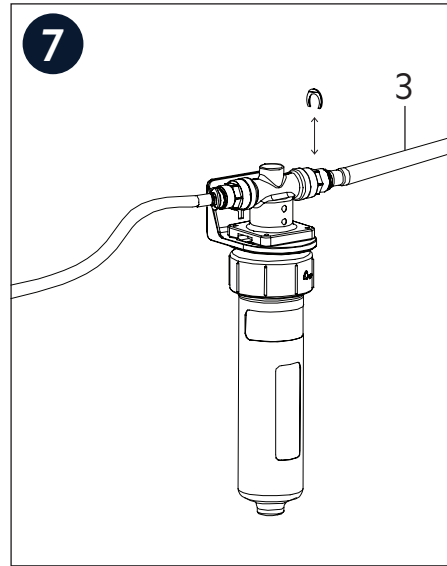

Remove blue tab. Connect hose (3) onto the filter outlet, then secure the connection. Reinsert the blue tab.

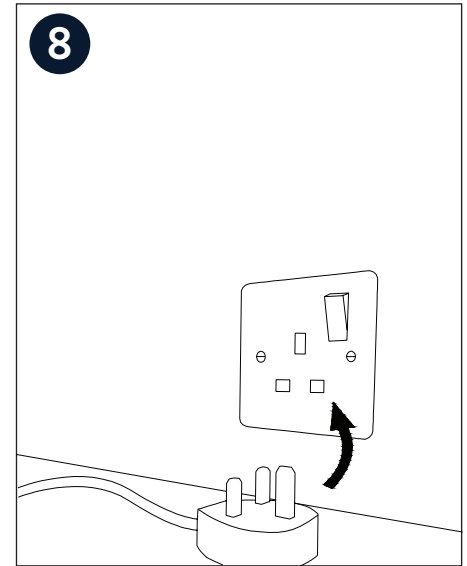

Before plugging in the boiling unit, ensure to fill the tank fully and run the water for an additional minute. Plug in the boiling unit and turn on the power.

How to Use your 3-1 Boiling Water Tap

- i) For filtered hot water, press the left handle button. Keep the button pressed and rotate the handle anti-clockwise for instant hot water.
- ii) For mixed water, pull the large lever backwards for mains hot water and forwards for mains cold water dispensing.

Regulation Requirements

It is important to ensure that the water supply to your tap is connected in accordance with the water regulation requirements, plumbing code and good plumbing practice. It is good practice that the supply of hot and cold water to the tap are equal (balanced) pressure in order to provide a consistent flow. Water supply should be from a common source, either mains or tank fed. If the water supply is not equal pressure then a Non Return Valve (check valve) should be fitted on the hot inlet.

Water Supply Pressures

The tap has been designed to function under the following conditions:

- Minimum supply pressure for cold water is 1.5 bar.
- Maximum supply pressure 5 bar (although we only recommend a maximum supply pressure of 3 bar).

IMPORTANT

Care & Maintenance of the Tap

Only clean the tap with a soft cloth, warm water and a mild detergent solution. Rinse the tap clean thoroughly afterwards with water. Do not use any abrasive or harsh chemical products, otherwise this will invalidate your guarantee.

These instructions are only intended as a guide, if there is any doubt then contact a certified plumber or service agent and avoid using the Instant Hot Water System until has been checked.

Boiling Water Tank

To switch the instant hot water heater on or off

Hold the “On/Off” key (A) once to switch the water heater on. Hold the “On/Off” key (A) once again at any time to switch the water heater off.

To set the water temperature

Touch the “Temperature” key (B) several times to scroll through the available temperatures:

45°C / 55°C / 65°C / 75°C / 85°C / 90°C / 91°C / 92°C / 93°C / 94°C / 95°C / 96°C / 97°C / 98°C

Once you had decided the desired temperature, leave it and the indicator will flash 3 times. The boiling unit is now set to the desired temperature.

Note

At all times, the “Actual Temperature” indicator (C) shows the actual temperature of the water in the heater unit reservoir.

When the boiling unit drops 5°C below the desired temperature, the unit will begin heating up again.

- A: On/Off Key
- B: Temperature Key
- C: Heating Display

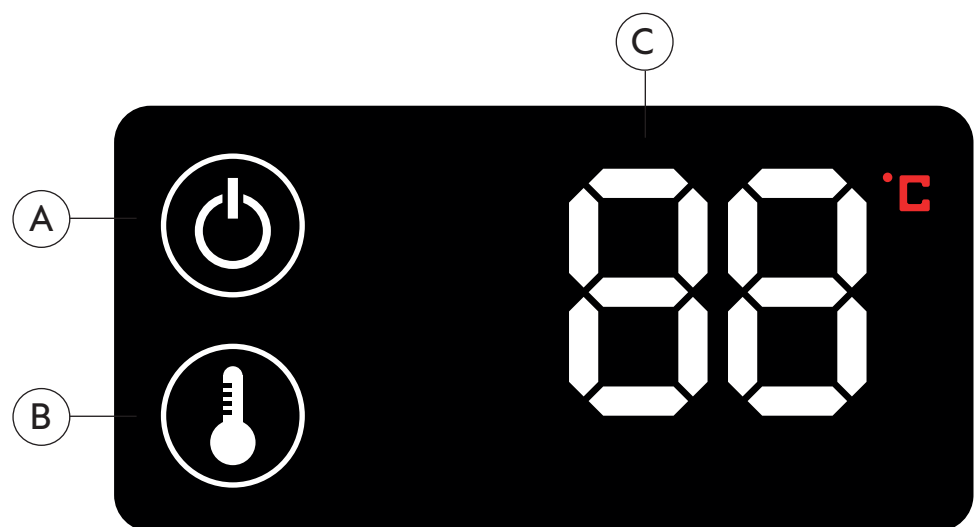

Troubleshooting

Below is a list of some of the possible malfunctions.

If the problem cannot be resolved as described, contact your dedicated KoGE retailer.

Problem	Possible Cause	Remedy
“Set Temperature” indicator flashes “E3”.	Insufficient water in the tank.	Prime the installation as described in the installation instructions.
Water and Steam is spitting from the instant hot water tap spout	Unit is boiling	Turn the instant hot water tap handle on and release the water. Adjust the water temperature on the display to a lower setting.
Water is not hot	The electronic instant hot water appliance is unplugged. There has been a power cut. The electronic unit has not been powered up	Make sure the instant hot water appliance is plugged in and connected to an earthed electricity outlet. Make sure that the circuit breaker and fuse are working correctly. Reset the temperature then press the confirm key. Turn on the power and then set the required temperature and confirm the boiler heats up.
Water is not hot	Water temperature setting on display panel is set too high.	Set the temperature to the required level and confirm the boiler heats up.
Water drips from the instant hot water tap spout	The expansion chamber isn’t draining the system correctly due to very small draw off of water. The spout is blocked.	Draw off 0.5L of water to clear and prime the system. avoid drawing off less than 150ml of water at a time. Remove and clean the aerator on the tap.
Slow flow from the spout	The water filter may be clogged from impurities in the inlet mains water.	The water filter must be changed every 6 months. Failure to do this will void the guarantee.
Water does not flow immediately	The instant hot water tap is designed for non-pressurised operation so there will be slight delay before the near boiling water starts to flow.	This is not a fault. Note that after a large volume of water has been drawn off there may be a slightly longer delay in the water appearing from the instant hot water spout.
No water flows	Water valves have been turned off. Inlet pipes have become twisted or blocked.	Turn on all the water valves. Ensure the pipes are not twisted or kinked and restricting flow. Remove and clean the aerator.
“Set Temperature” indicator flashes “E4”.	Product Catastrophic Failure	Contact KoGE retailer if under warranty period.

Specifications

Supply	230V ~ 50Hz
Power	1.5 kW
IP Rating	X4
Tank Capacity	2.4 Litres
Immediate Draw Off	1.7 Litres
Minimum Supply Pressure	0.15 MPa (1.5 Bar)
Maximum Supply Pressure	0.5 MPa* (5 Bar)
Hot & Cold Connections	½" BSP
Approvals	UKCA CE

* If the pressure is above 0.5 MPa (5 Bar) then a pressure reducing valve is required.

Guarantee

This product is covered by a standard parts of replacement warranty for a period of 12 months from the date of purchase. If there is manufacturing defect within the warranty period we will send spare parts, repair and return the unit or, at our descretion, supply a replacement product. Incorrect installation, frost damage, the consequences of limescale deposits or failure to follow correct operating and maintenance instructions are excluded.



Spare Components