

BRISTAN

Installation Instructions and User Guide

Traditional Shower Riser

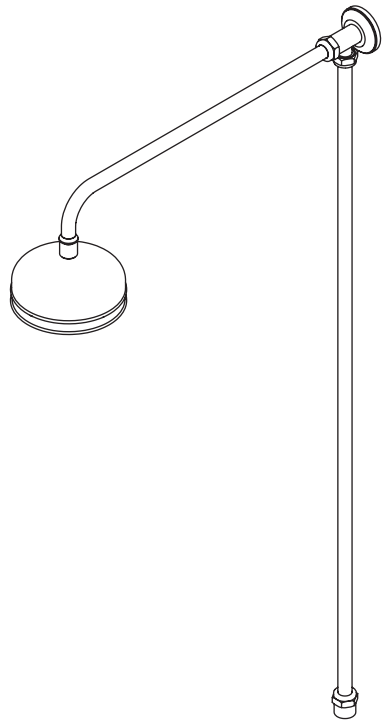

Models covered: TRD RISE C &
TRD RISE G

Please keep this booklet for future
reference.

Installer, when you have read these
instructions please ensure you leave them
with the user.

Installation - Antique Diverter & Rigid Riser

Rigid Riser Installation

1. Push the rigid riser into the top of the shower valve (not supplied).
2. Fit the top wall bracket onto the top of the rigid riser and place against the wall surface. Mark the position and remove from the rigid riser.

⚠ Warning: Please check for any hidden pipes and cables before drilling holes into the wall.

Drill suitable holes and insert the wall plugs. Push the Top bracket back onto the rigid riser and attach to the wall using the fixings supplied.

3. Push the arm into the top bracket, ensuring the nut and olive are fitted to the arm. Tighten the nut fully using a suitable spanner.

4. Screw the shower rose onto the arm, ensuring the sealing washer is fitted between the rose and arm.

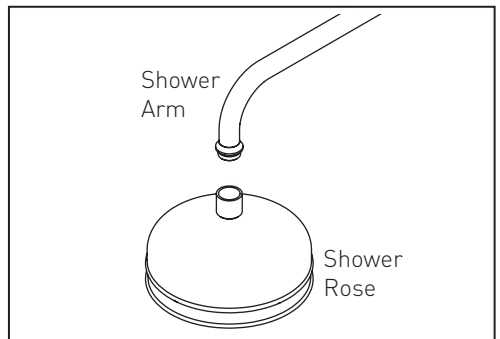
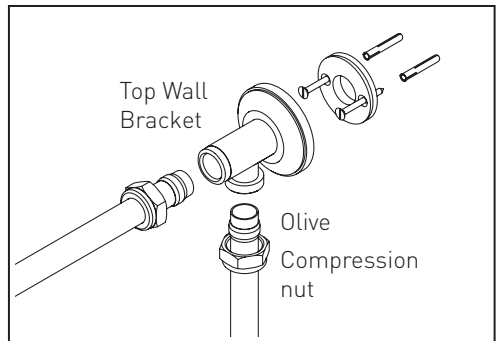
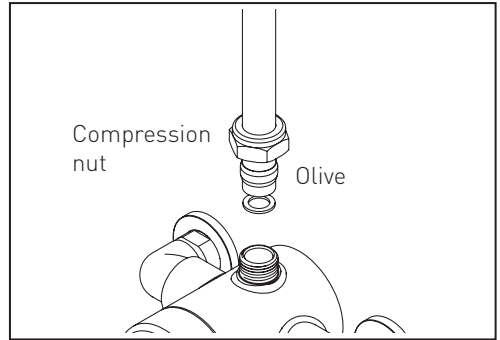

Guarantee

At Bristan, we want to make things as easy as possible for our customers. That's why we design products that are easy to fit and use, and that are quality tested to make sure they won't let you down. It's also why we offer solid guarantees on all products, effective from the date of purchase, to give you peace of mind.

All products are manufactured to the highest standards and a 5 year parts only guarantee covers any defect in manufacture.

Guarantee Terms and Conditions

This guarantee is in addition to your statutory and other legal rights and is subject to the following conditions:

- The product was purchased within the United Kingdom or Republic of Ireland.
- The guarantee applies solely to the original purchaser with proof of purchase.

- The guarantee on any replacement parts or product ends at the original expiry date
- Any part found to be defective during the guarantee period will be replaced without charge, providing that the product has been installed in accordance with the instructions given in this guide and used as the manufacturer intended.

The guarantee does not cover

- Damage or defects caused by:
 - General wear and tear (including special non-chrome finishes;
 - Components such as filters, seals, 'O' rings and washers)
 - Incorrect installation
 - Repair using non-Bristan part
 - Accidental or wilful misuse
 - Corrosion and the use of inappropriate cleaning products.
 - System debris including the build up of limescale (which can be controlled through regular servicing and maintenance)
- Compensation for loss of use of the product or consequential loss of any kind.

In the interests of continuous product improvement, Bristan reserves the right to alter product specifications without notice.

The Bristan Product Guarantee does not affect your statutory rights as a consumer.

Part Number: FI TRD RISE
Issue: D1

BRISTAN

Bristan Group Ltd.
Birch Coppice Business Park
Dordon
Tamworth
Staffordshire
B78 1SG
Web: www.bristan.com
Email: enquire@bristan.com

A Masco Company

Useful contact details:

Customer Service:

0844 7016273

Customer Service Email:

Customercare@bristan.com

Customer Service Fax:

0844 7016275

Reception:

0844 7016274

Join us on...

