

CHR EFSNK C

CHERRY Tap Range Cherry EasyFit Monobloc Sink Mixer Chrome



Specification

Product Type:	Kitchen Taps
Main Construction Material:	Brass
Mount Type:	Deck Mounted
Handle Type:	Lever
Connection Inlet:	1/2" BSP Flexible Tails
Connection Outlet:	N/A
Number of Tap Holes:	1
Valve/Cartridge Type:	35mm Cartridge
Plumbing System Requirements:	All, Preferably Balanced
Working Pressure Range:	Min 0.3 Bar, Max 5.0 Bar
Maximum Hot Water Temperature: °C	65
Maximum Static Pressure: (bar)	10
Flow Type:	Single Flow
Isolation Included:	Yes

Features:

- Long life ceramic cartridge for added durability and ease of use
- Metal fixing nut for added durability
- Easyfit base included
- Flexible tails included

Product Certifications:



Dimensions (measurements in mm)

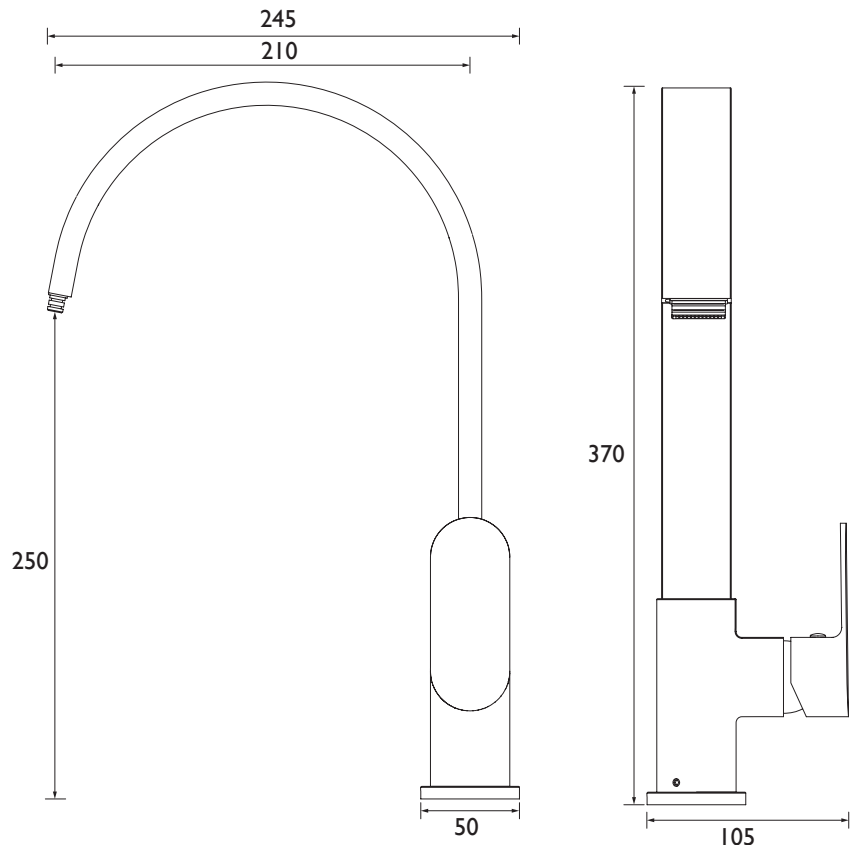

Flow Rates (l/min)

System Pressure (bar)	0.2	0.5	1	2	3	5
CHR EFSNK C	6	7.7	10.9	15.5	18.9	24.5

For more products, visit our website:
<http://www.bristan.com>



TECHNICAL
DATA
SHEET



BRISTAN
TAPS & SHOWERS D5