

- F Notice de montage (version pivotante) ● GB Installation instructions (pivoting version)
- E Manual de instalación (versión giratoria) ● I Istruzioni di montaggio (versione girevole)
- NL Installatie voorschriften (draaibare versie) ● D Installationsanleitung (schwingtür)

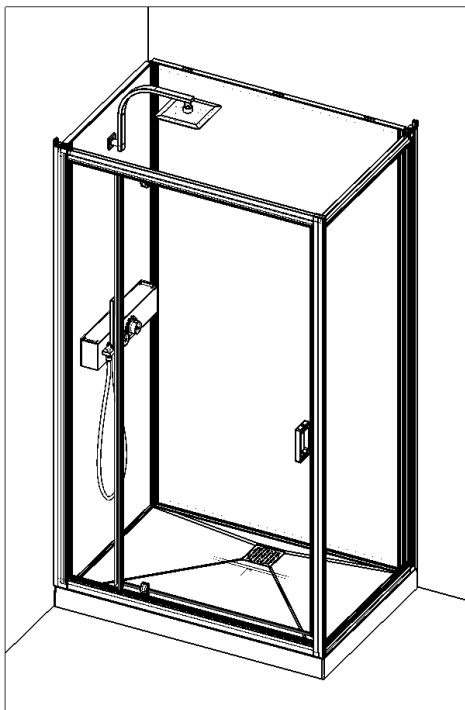

Notre service technique est à votre écoute aux numéros qui sont au dos de cette notice d'installation

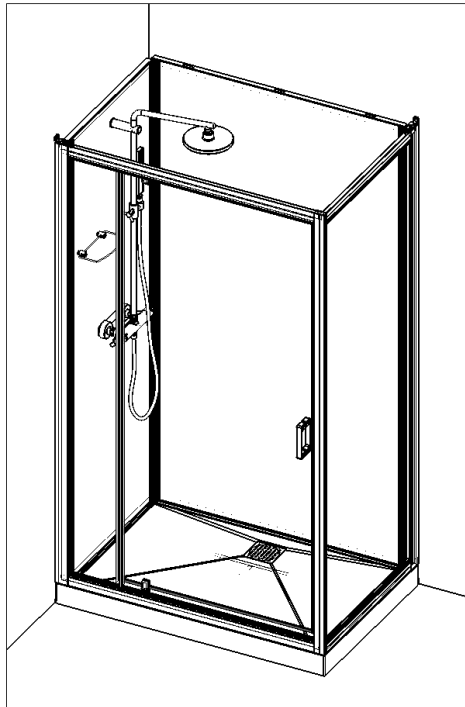

- Attention aux étapes :
- GB Check installation steps :
- E Atención a los pasos :
- I Attenzione ai passi :
- NL Aandacht voor de stappen :
- D Achtung vor den Schritten :

P. 12 - 13 - 14

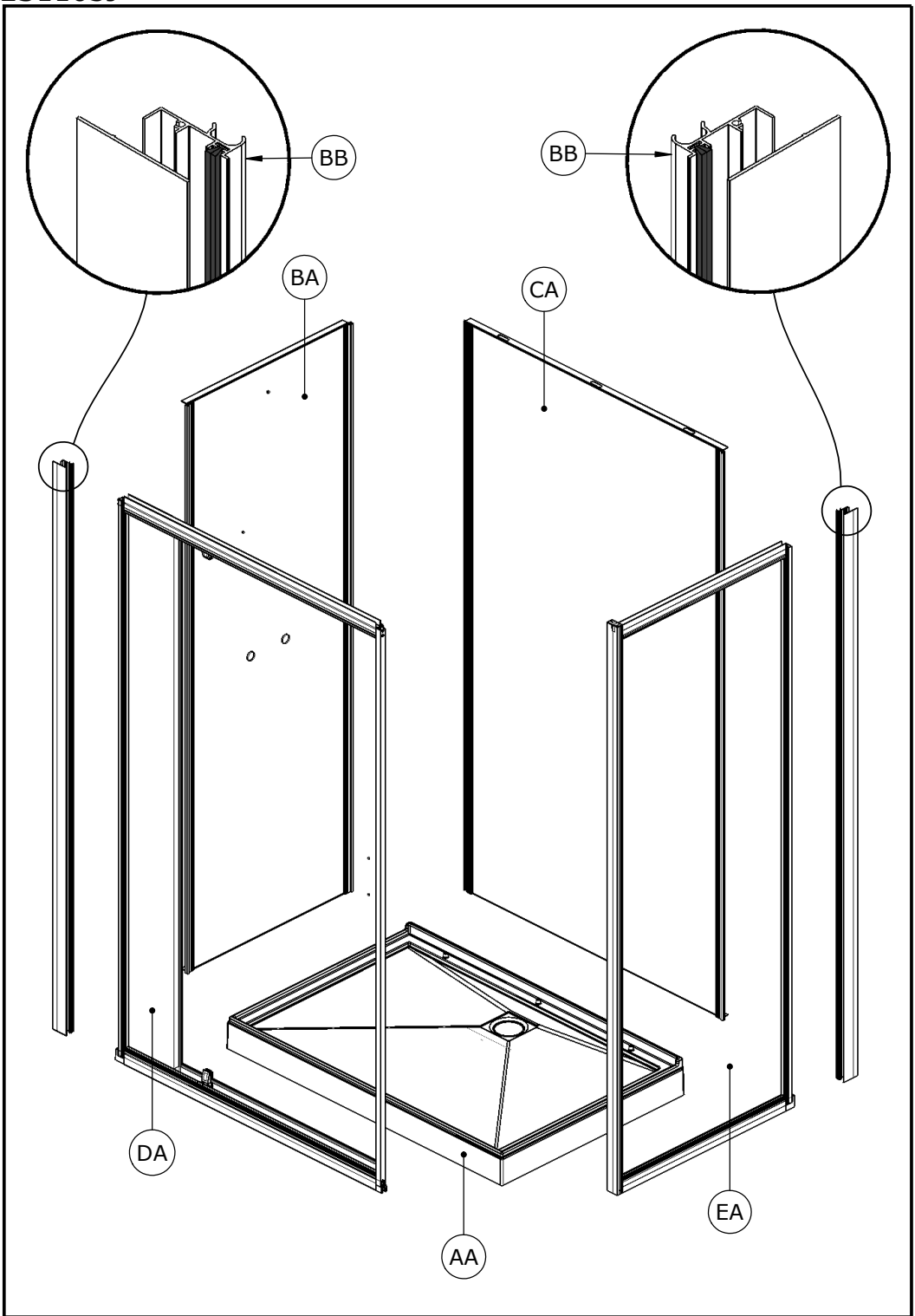

EDEN 2

Rep	100x80		120x80		120x90		Qté
	BAS/LOW	HAUT/HIGH	BAS/LOW	HAUT/HIGH	BAS/LOW	HAUT/HIGH	

COLIS 1

AA	REC420	REC426	REC541	REC580	REC559	REC581	1
AB	BOND14						1
AC	TOL54						1
AD	TUY62						1
AE	JOI292						1

COLIS 2

BA	9801	C9802	1
BB	5003C02		2
BC	S1555-A		1

COLIS 3

CA	C9761	C9762	1
----	-------	-------	---

COLIS 4

DA	C9767	C9768	1
DB	JOI311		1
DC	JOI233		1
DD	JOI233		1
DE	PGN36C		1

COLIS 5

EA	C9788	C9790	1
EB	S1556		1

BOITE B1171

FA	MIT89		1
FB	KIT181		1
FD	KIT76		1
FE	KIT180		1
FF	FLEX05		1
FG	VER4288		1
FH	AV085		2
FJ	SET89		1
FK	TOL89		1
FO	TUY66 + TUY67		1

EDEN 2+

Rep	100x80		120x80		120x90		Qté
	BAS/LOW	HAUT/HIGH	BAS/LOW	HAUT/HIGH	BAS/LOW	HAUT/HIGH	
COLIS 1							
AA	REC420	REC426	REC541	REC580	REC559	REC581	1
AB	BOND14						1
AC	TOL54						1
AD	TUY62						1
AE	JOI292						1

COLIS 2							
BA	C9803				C9804		1
BB	5003C2						2
BC	S1555-A						1

COLIS 3							
CA	C9761			C9762			1

COLIS 4							
DA	C9767			C9768			1
DB	JOI311						1
DC	JOI233						1
DD	PGN36C						1

COLIS 5							
EA	C9788				C9790		1
EB	S1556						1

BOITE B1172							
FC	S2029						1
FD	KIT125						1
FF	KIT124						1
FG	FLEX05						1
FH	KIT76						1
FI	KIT113						1

Colis 1

S1552

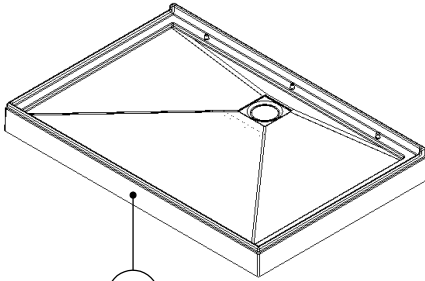

AA

+

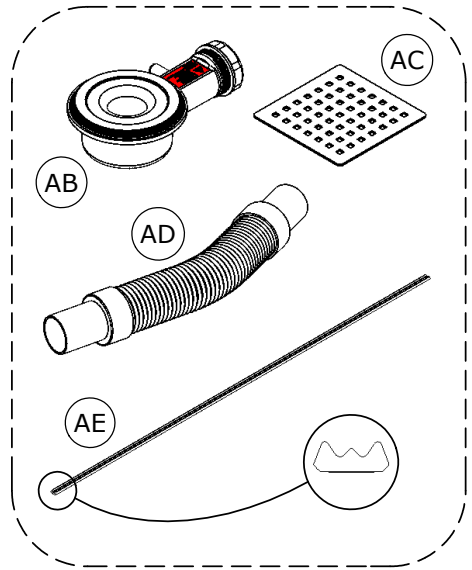

AC

AB

AD

AE

Colis 2

S1555-A

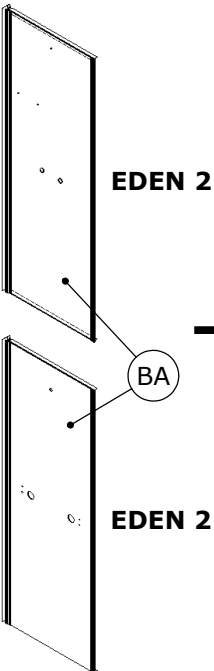

EDEN 2

EDEN 2+

+

BB

+

BC

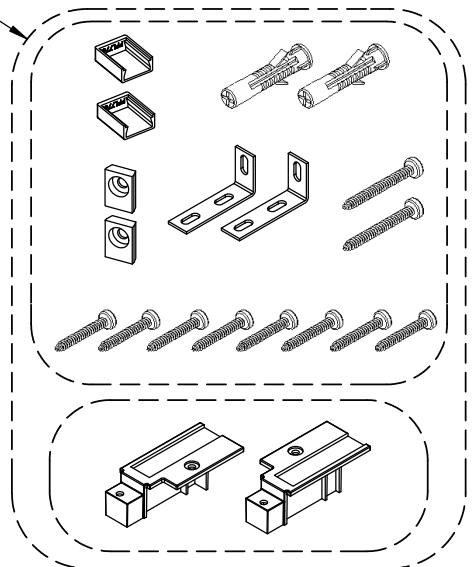

x2

Colis 3

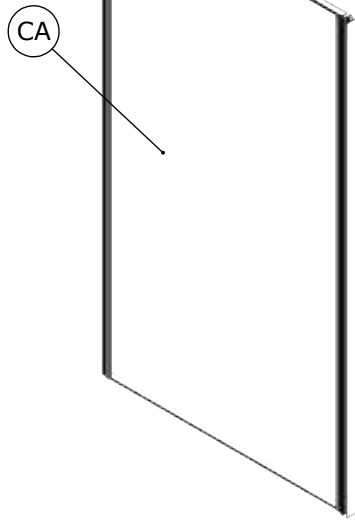

Colis 4

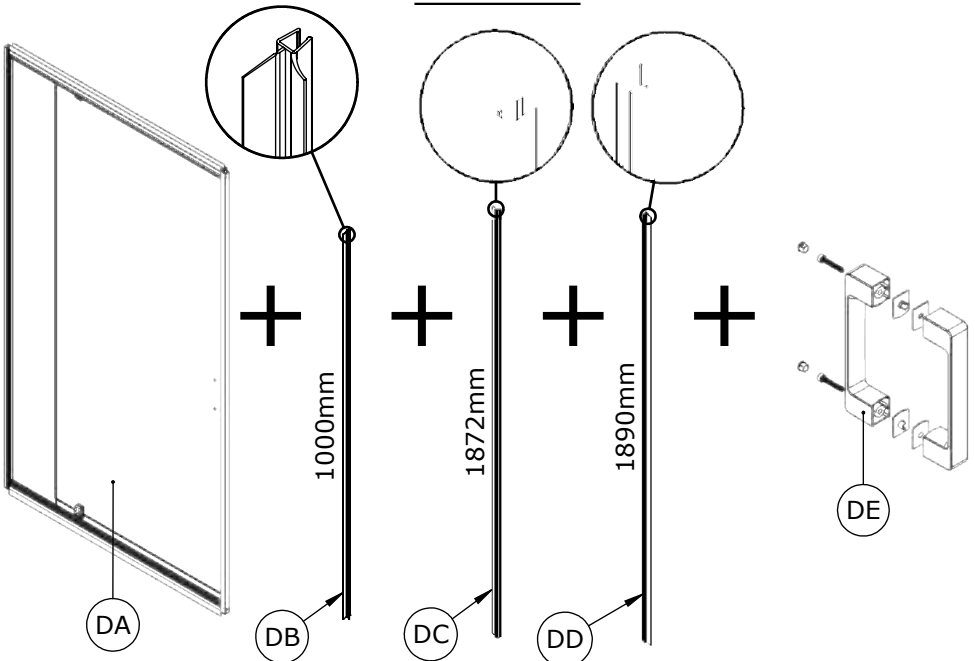

Colis 5



+

S1556

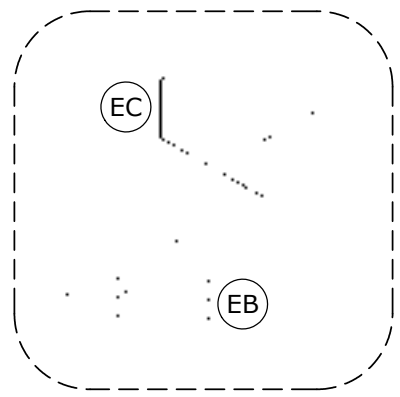

Boite B1171

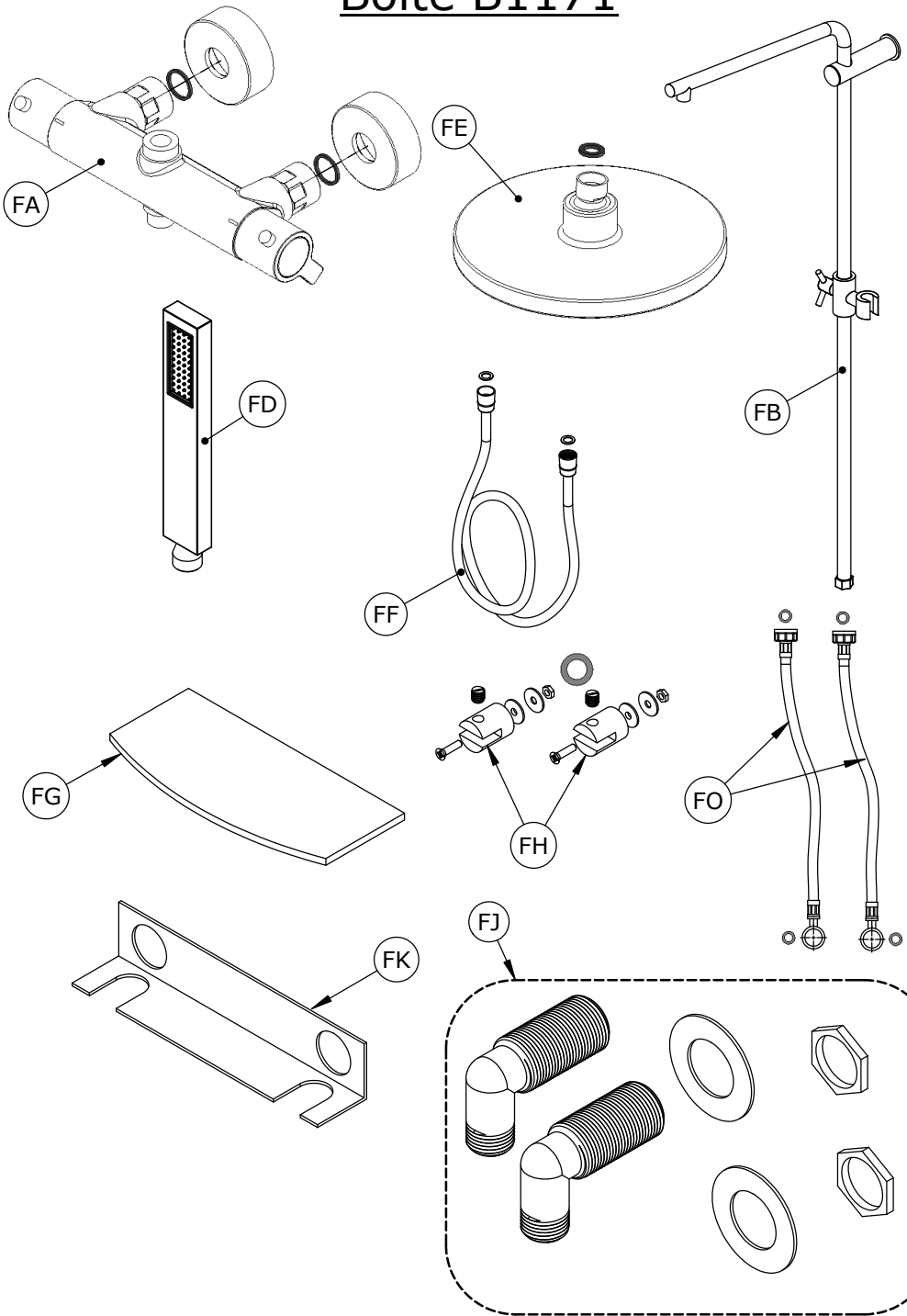

Boite B1172

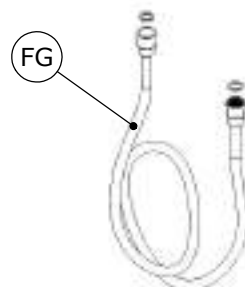
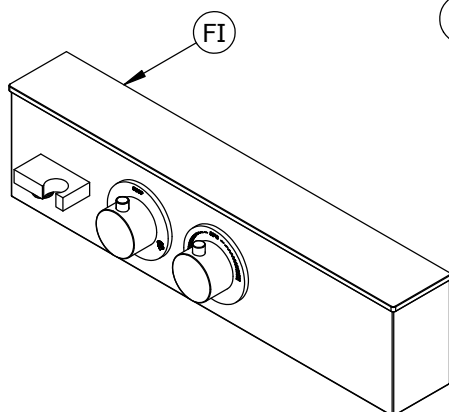
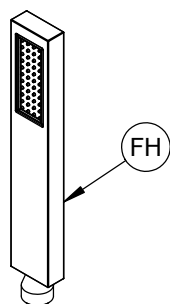
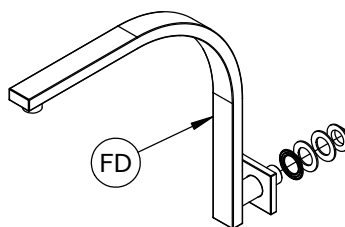
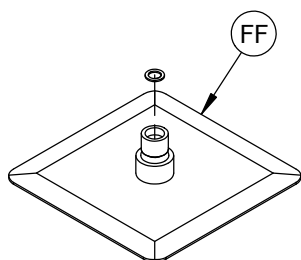
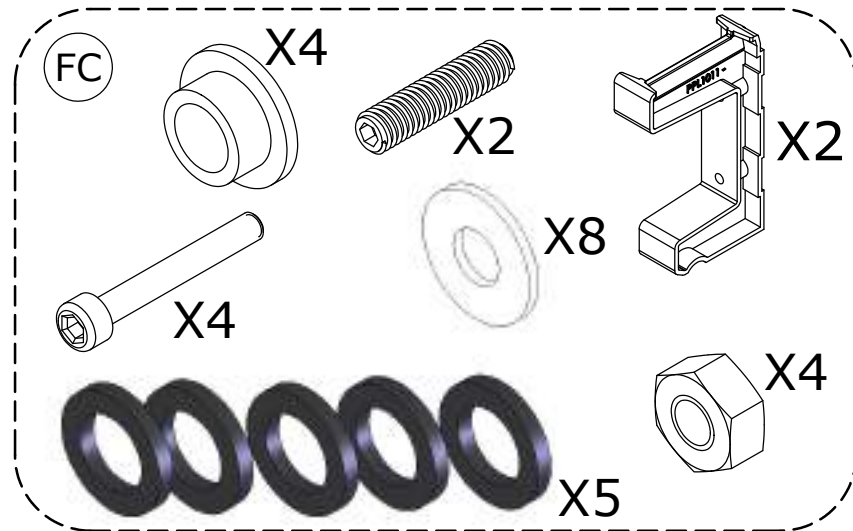

- F** Matériel nécessaire
- GB** Tools required
- E** Material necesario
- I** Materiale necessario
- NL** Nodige gereedschap
- D** Erforderliche Werkzeuge

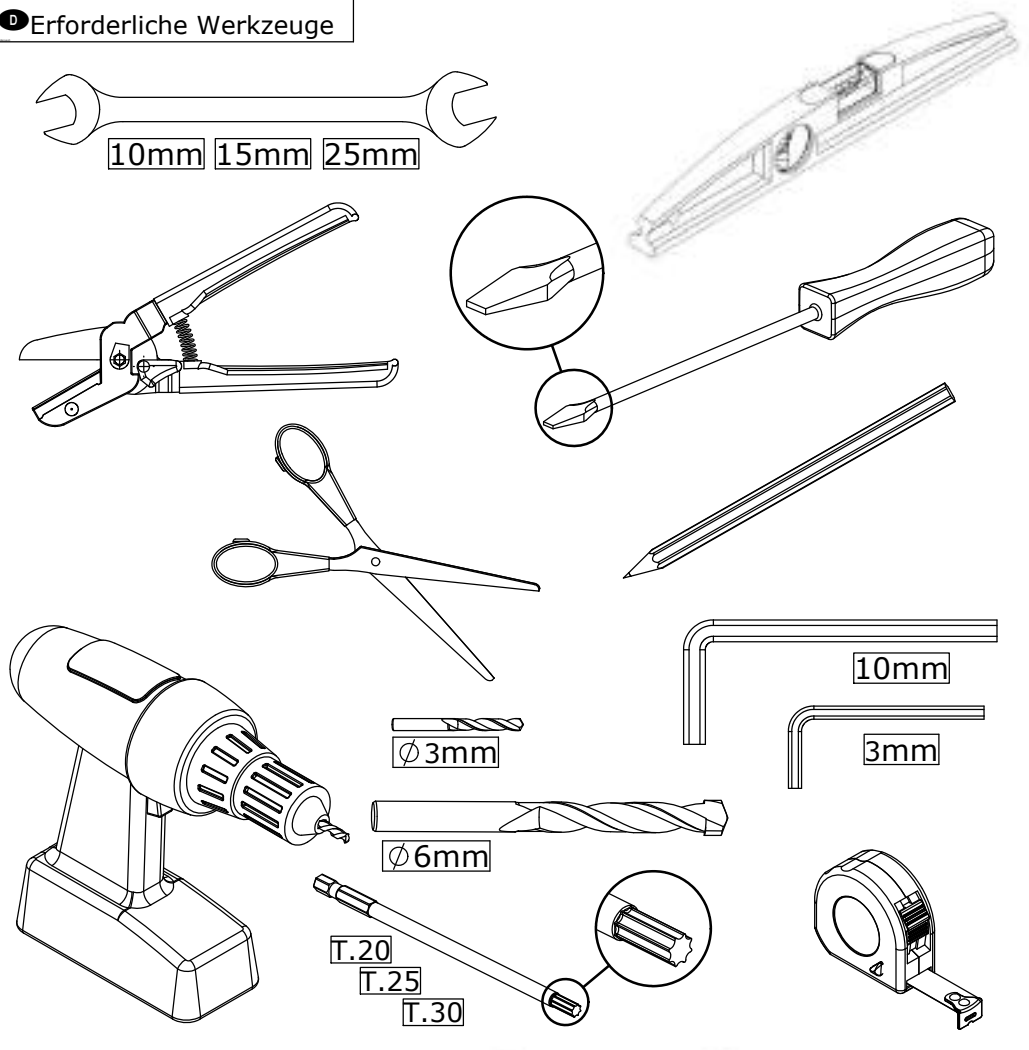

F REVERSIBILITE **GB** REVERSIBILITY **E** REVERSIBILIDAD
I REVERSIBILITA **NL** OMKEERBAARHEID **D** WAHLWEISE MONTAGE

F MONTAGE A GAUCHE
GB LEFT HAND
E MONTAJE A LA IZQUIERDA
I MONTAGGIO A SINISTRA
NL MONTAGE LINKS
D MONTAGE LINKS

F MONTAGE A DROITE
GB RIGHT HAND
E MONTAJE A LA DERECHA
I MONTAGGIO A DESTRA
NL MONTAGE RECHTS
D MONTAGE RECHTS

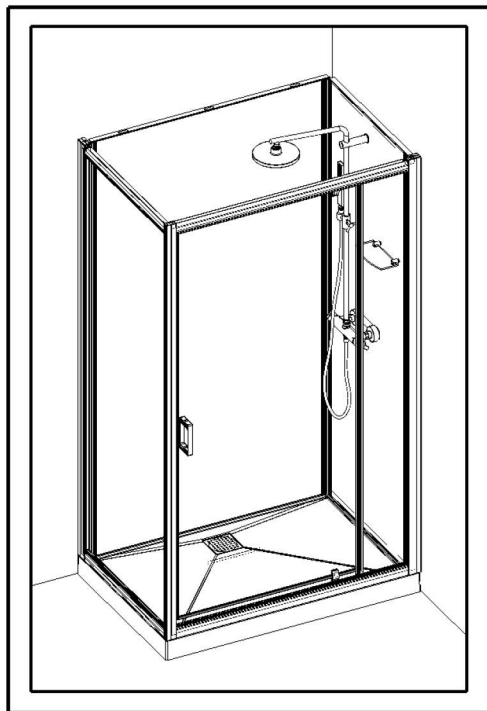
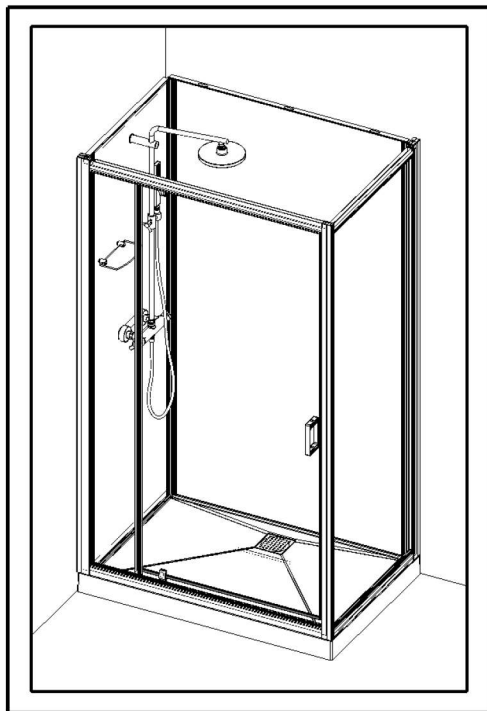

F Vous avez la possibilité de réaliser un montage à droite ou un montage à gauche. Notre notice d'installation décrit un montage à gauche. Si vous voulez réaliser un montage à droite, il vous suffit d'inverser le montage.

GB This cubicle can be installed either left or right hand. These installation instructions show a left hand installation.

E Puede realizar un montaje a la derecha o un montaje a la izquierda. Nuestro folleto de instalación describe un montaje a la izquierda. Si desea montar su cabina a la derecha sólo tendrá que realizar el montaje al contrario.

I Avete la possibilità di effettuare il montaggio a destra o a sinistra. Il nostro manuale descrive il montaggio a sinistra. Se volete realizzare il montaggio a destra è sufficiente invertire varie fasi di montaggio.

NL U kunt de douchecabine rechts of links monteren. Onze handleiding beschrijft de links montage van de cabine. Keer de montage om als u de cabine rechts wilt monteren.

D Sie haben die Möglichkeit, eine Montage auf der linken Seite oder eine Montage auf der rechten Seite durchzuführen. Unsere Montageanleitung beschreibt eine Montage auf der linken Seite. Wenn Sie die Montage lieber auf der rechten Seite durchführen wollen, müssen Sie nur den Montageprozess umkehren.

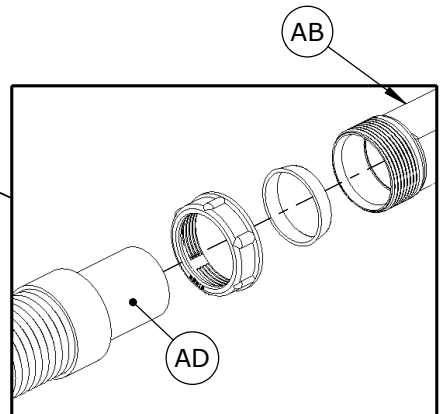
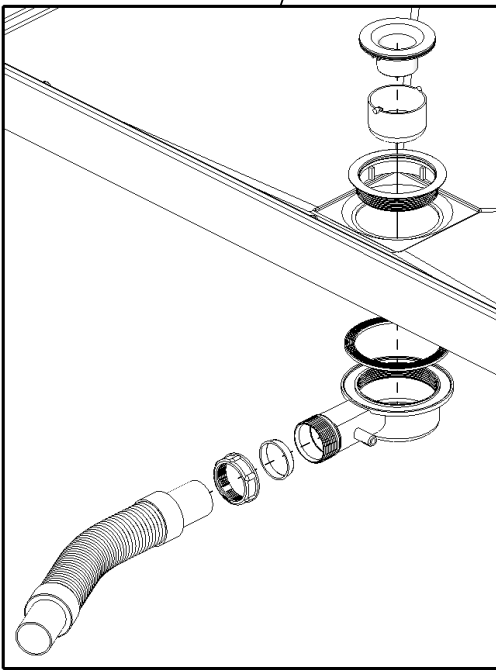
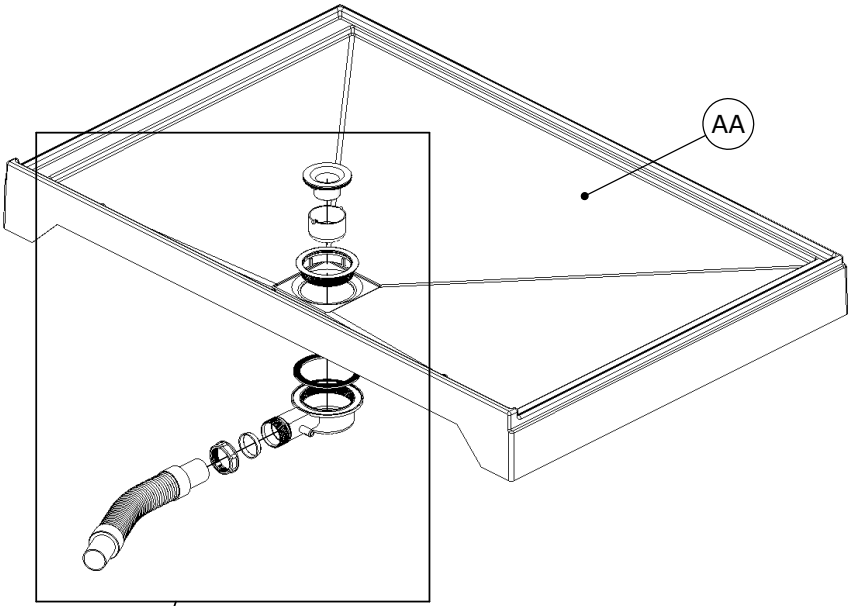

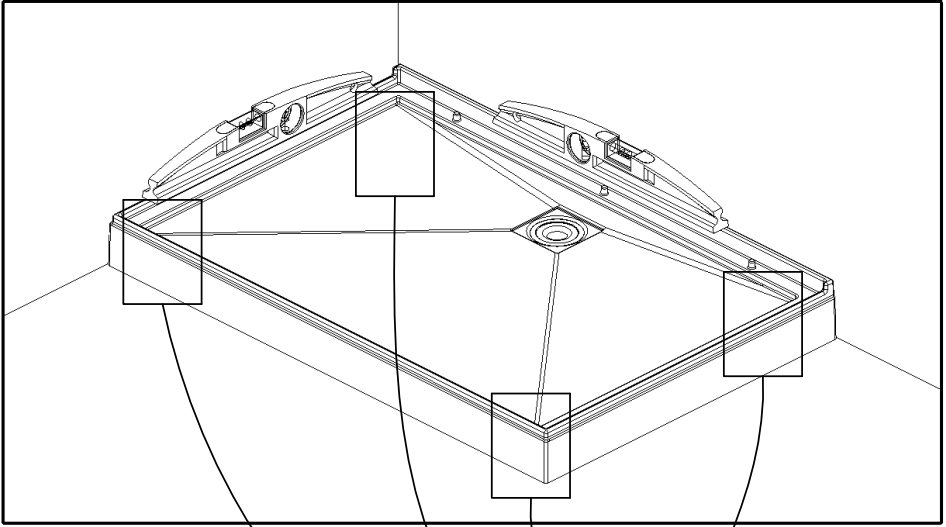

- Mettre les pieds en contact avec le sol
- Feet in contact with the ground
- Pies en contacto con el suelo
- Piedi a contatto con il terreno
- Voeten in contact met de grond
- Die sockelfüÙe im Kontakt mit dem Boden bringen

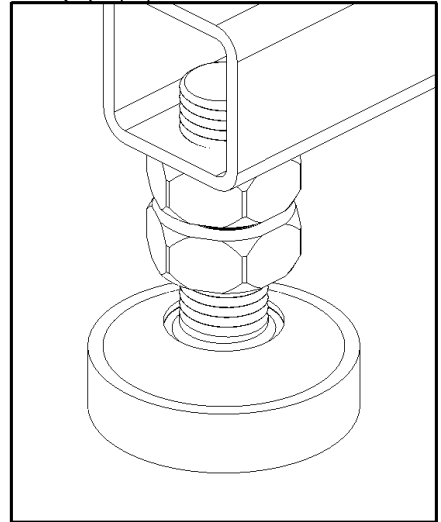

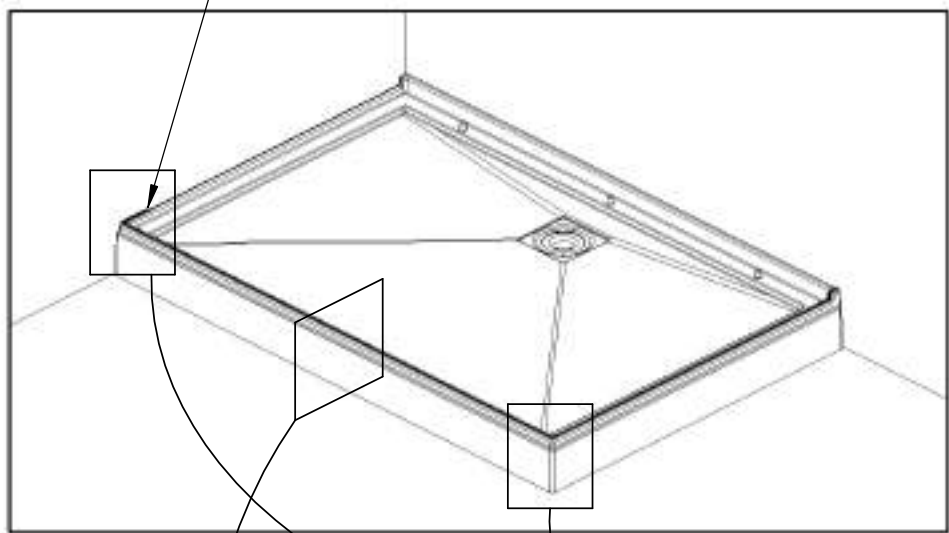
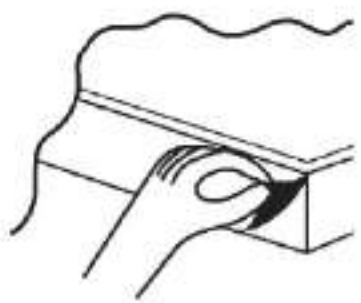

AE

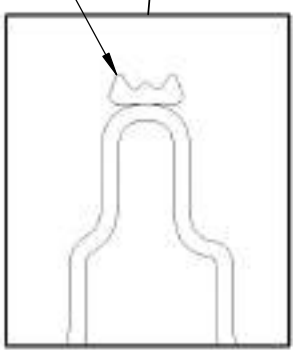

AE

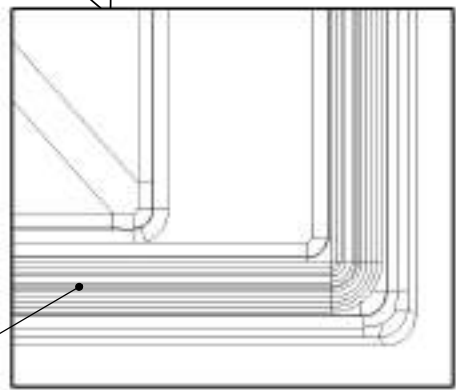

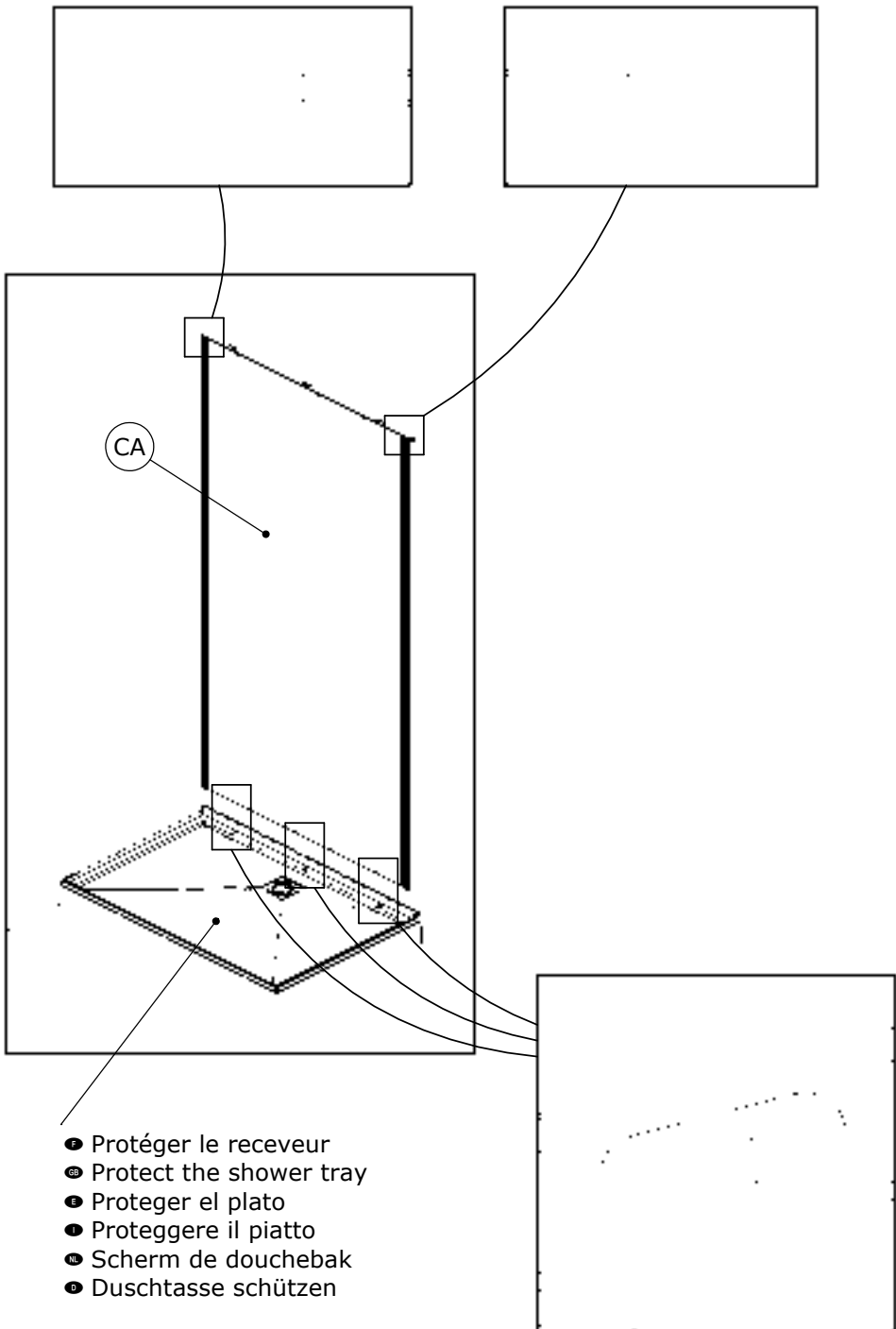

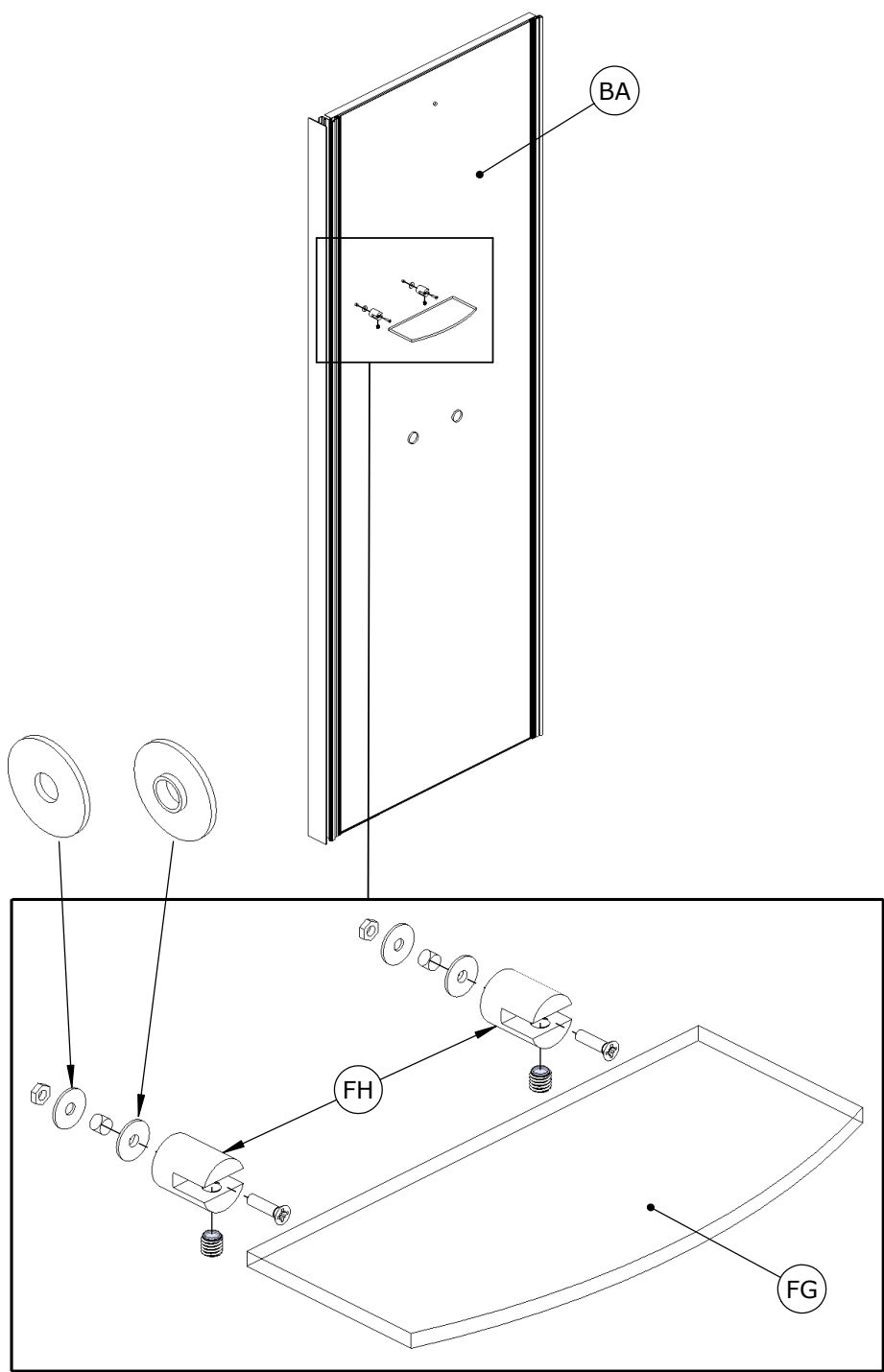

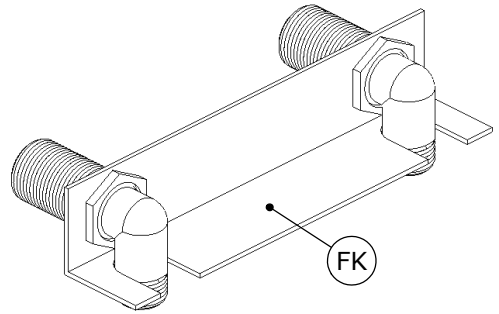
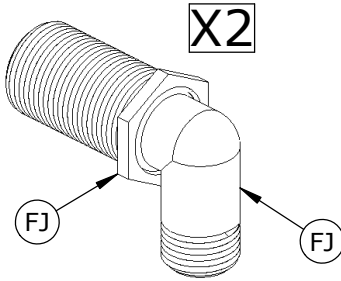

1

2

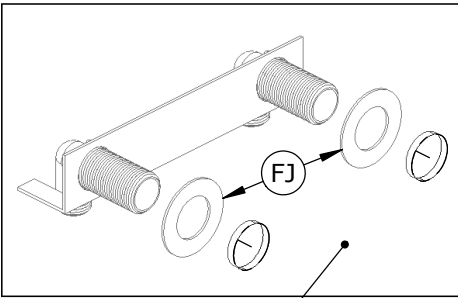

- Intérieur ● Inside
- Interior ● Interno
- Binnenkant ● Innen

3

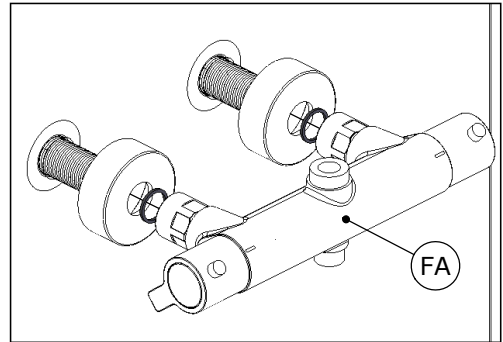

4

- Contact ● Contact ● Contacto
- Contatto ● Contact ● Kontakt

- Serrer ● Tighten ● Apriete
- Serrare ● Aandraaien ● Festziehen

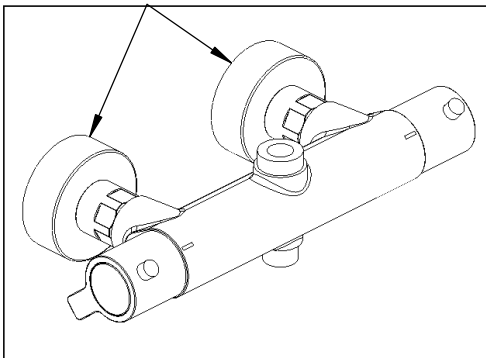

5

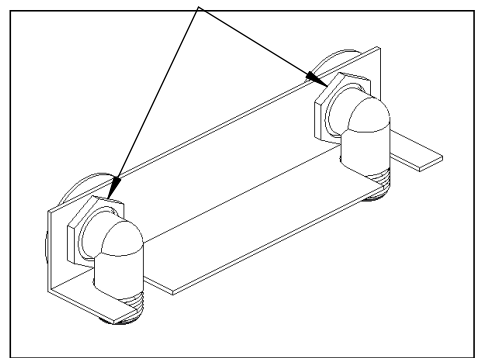

6

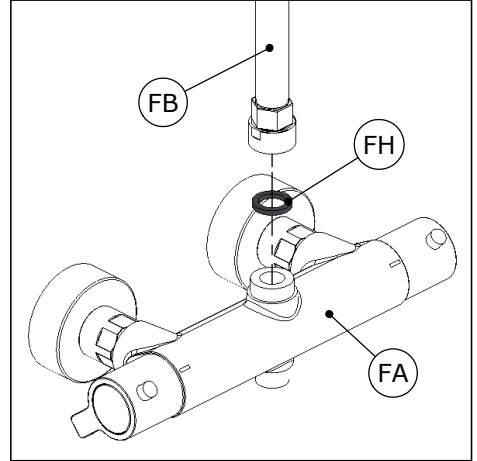
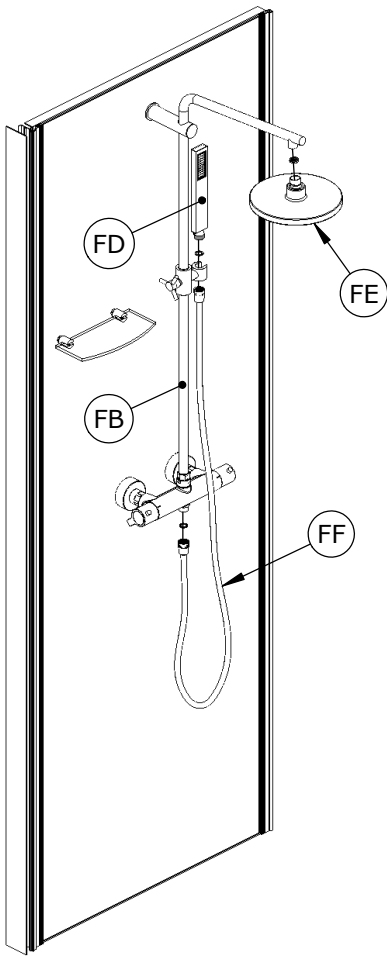

1

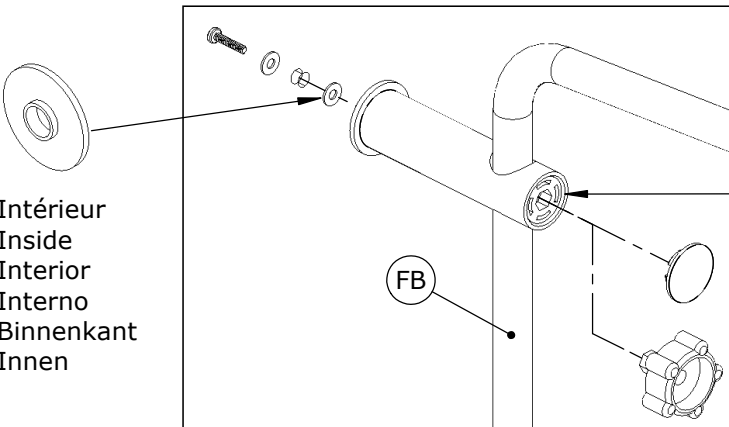

- Intérieur
- ⊖ Inside
- ⊖ Interior
- Interno
- ⊖ Binnenkant
- Innen

- Serrer
- ⊖ Tighten
- ⊖ Apriete
- Serrare
- ⊖ Aandraaien
- Festziehen

2

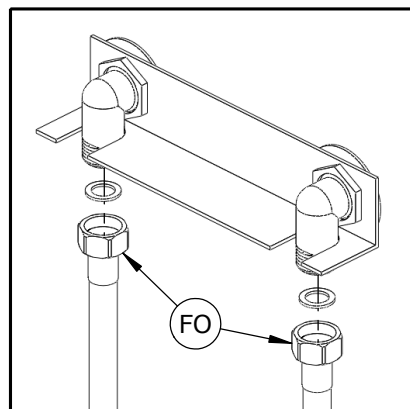
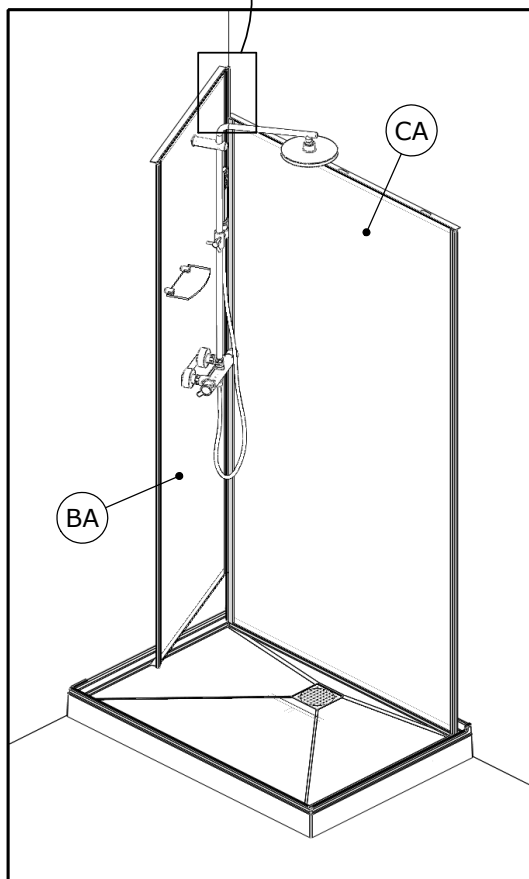
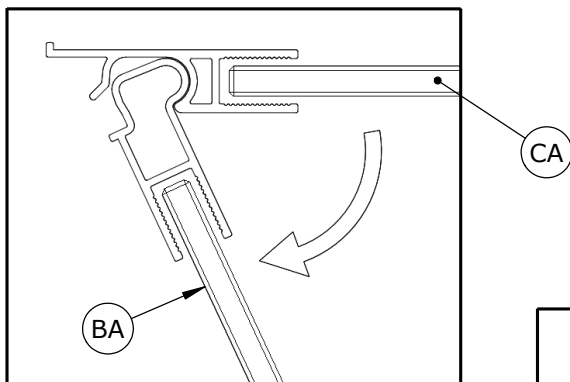

- Vérifier le bon serrage de chaque connexion afin d'éviter tout problème de fuite lors de la mise en eau
- Check that each connection is properly tightened in order to avoid any potential leakage problems when put under pressure
- Comprobar cada conexión sea correcta para evitar los problemas de fuga una vez se conecte con el agua
- Controllare il buon serraggio di tutti i collegamenti allo scopo di evitare perdite d'acqua
- Controleren op waterdichtheid alvorens u de douchecabine definitief plaatst. Hiermee vermijdt u mogelijke lekkages nadat het water op druk wordt aangesloten
- Zur Vermeidung kein Leck problem bei der Flutung, die gute klemmen von jede Verbindung überprüfen

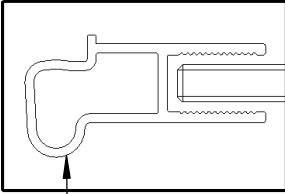

- Intérieur ● Inside
- Interior ● Interno
- Binnenkant ● Innen

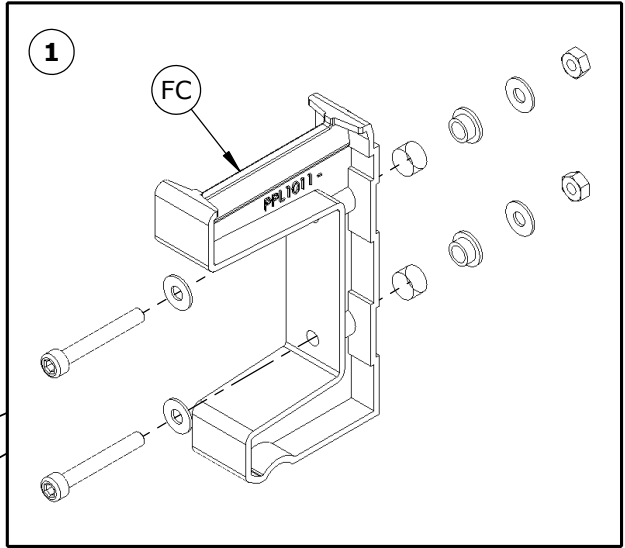
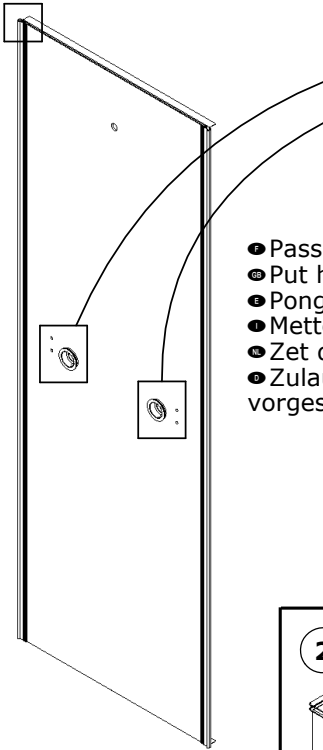

- Passer les flexibles dans les orifices
- Put hoses into holes
- Ponga las mangueras en los agujeros
- Mettere i flessibili nei fori
- Zet de flexibele in de gaten
- Zulaufschläuche durch die vorgesehenen Öffnungen führen

- Flexibles eau chaude/eau froide
- Hoses hot water/cold water
- Mangueras agua caliente/agua fria
- Flessibili acqua calda/acqua fredda
- Flexibele warm water/koud water
- Schlauch Warmwasser/Kaltwasser

- Flexible de zénithale
- Shower head hose
- Manguera de ducha
- Flessibile doccia
- Flexibele douchekop
- Dusche kopf schlauch

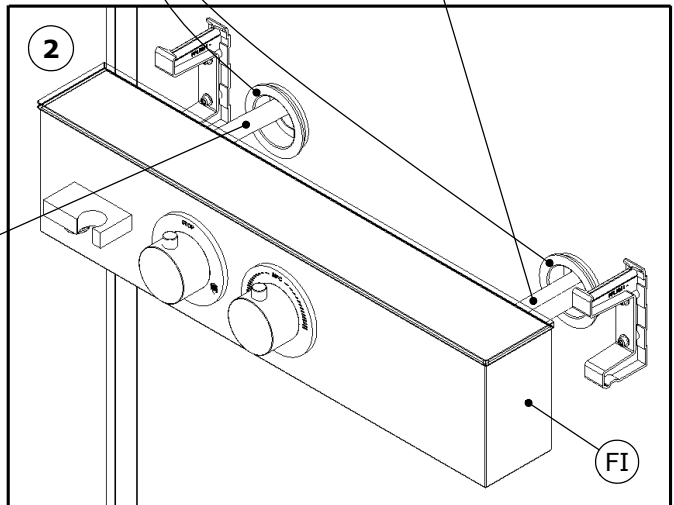

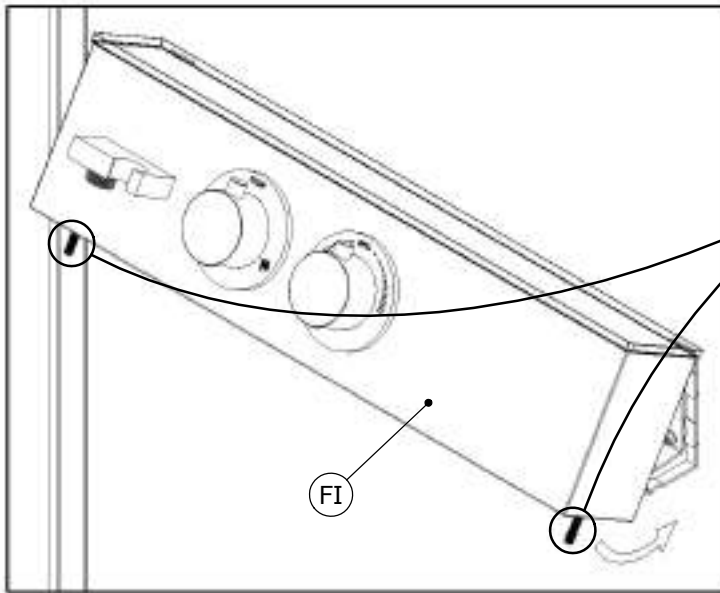

- Serrer jusqu'à affleurement
- Tighten until flush
- Apriete hasta ras
- Serrare a filo
- Draai tot flush
- Festziehen bis bündig

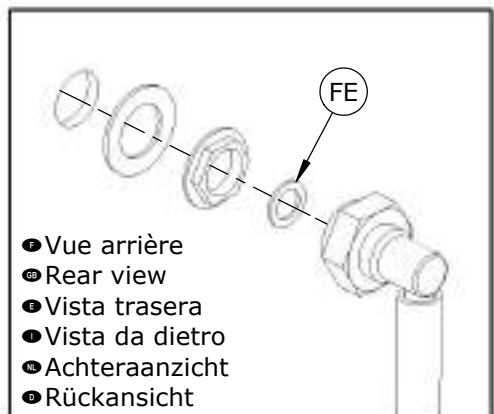
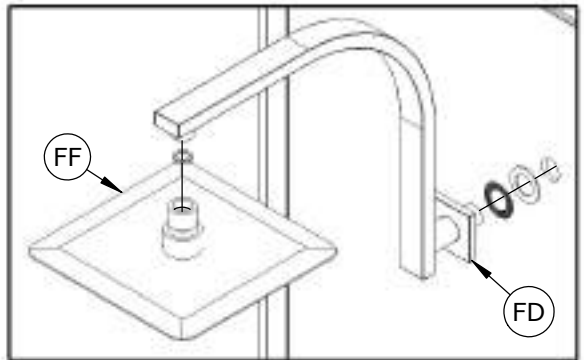
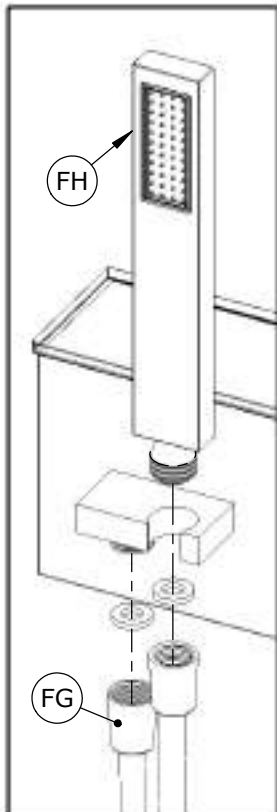

- Vue arrière
- Rear view
- Vista trasera
- Vista da dietro
- Achteraanzicht
- Rückansicht

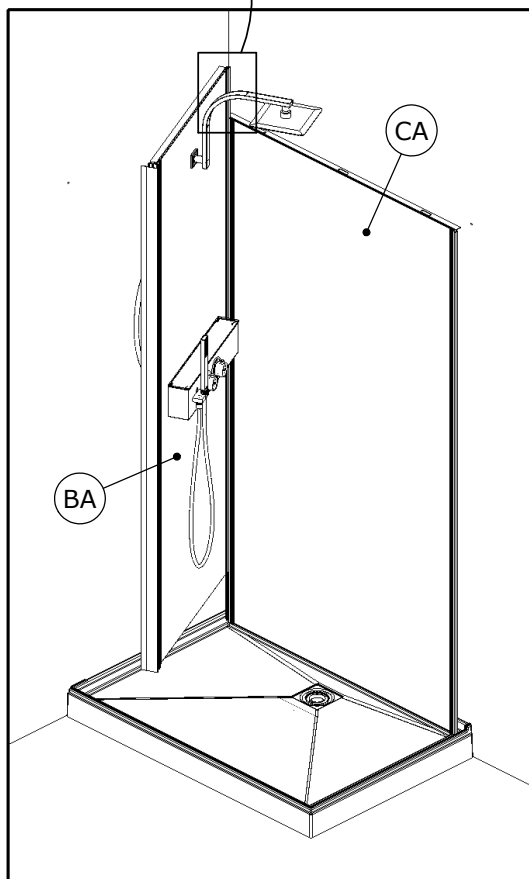
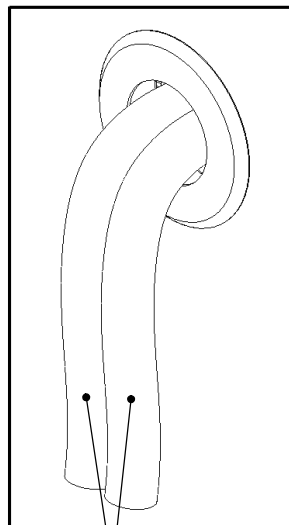
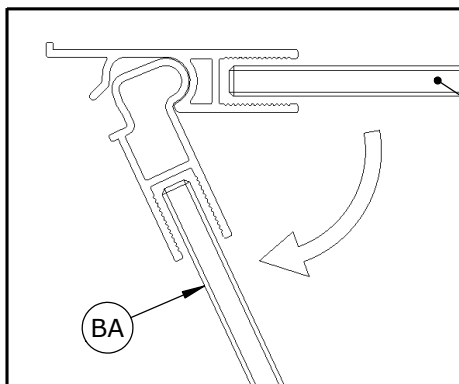

- Raccorder vos flexibles d'alimentation à votre système
- Connect the hoses water to your system
- Conecte el agua mangueras a su sistema
- Collegare i flessibili di acqua al vostro sistema
- Sluit de slangen watervoorziening aan uw systeem
- Zulaufschläuche an System anschließen

- Vérifier le bon serrage de chaque connexion afin d'éviter tout problème de fuite lors de la mise en eau
- Check that each connection is properly tightened in order to avoid any potential leakage problems when put under pressure
- Comprobar cada conexión sea correcta para evitar los problemas de fuga una vez se conecte con el agua
- Controllare il buon serraggio di tutti i collegamenti allo scopo di evitare perdite d'acqua
- Controleren op waterdichtheid alvorens u de douchecabine definitief plaatst. Hiermee vermijdt u mogelijke lekkages nadat het water op druk wordt aangesloten
- Zur Vermeidung kein Leck problem bei der Flutung, die gute klemmen von jede Verbindung überprüfen

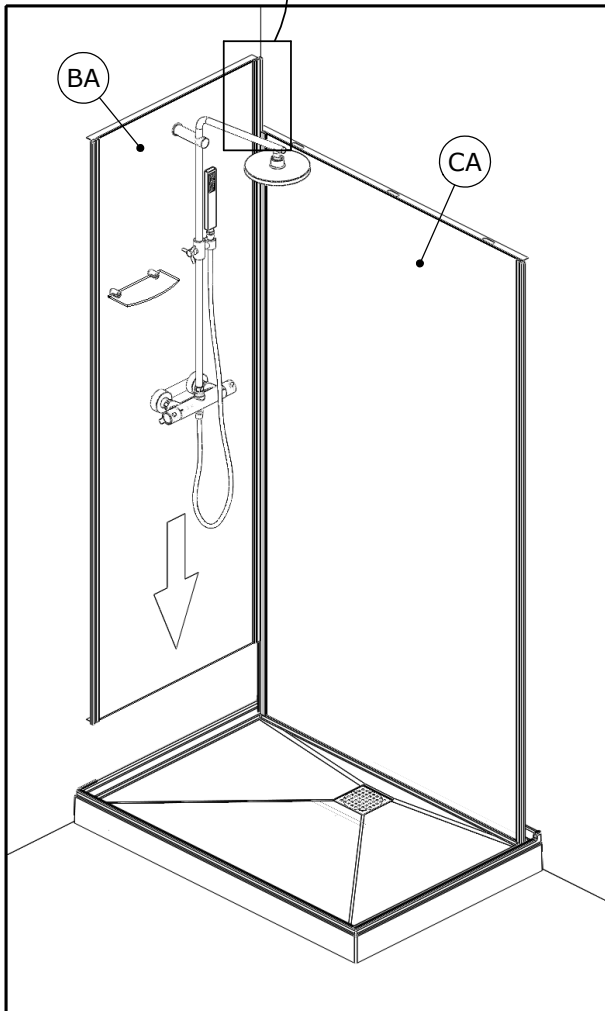
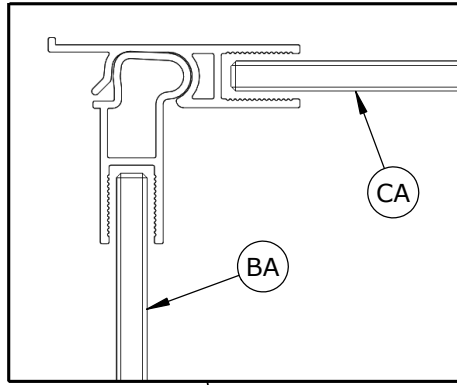

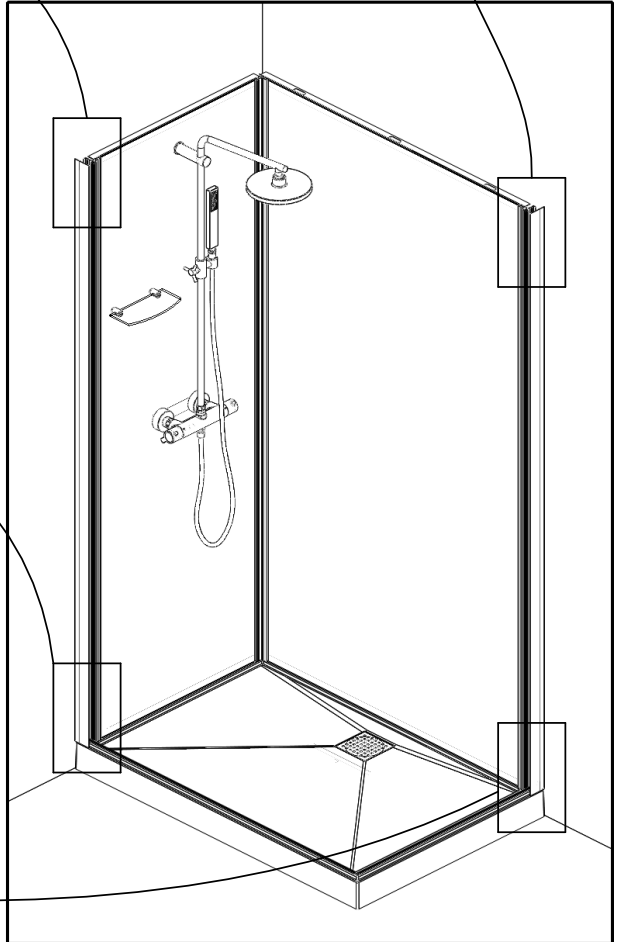
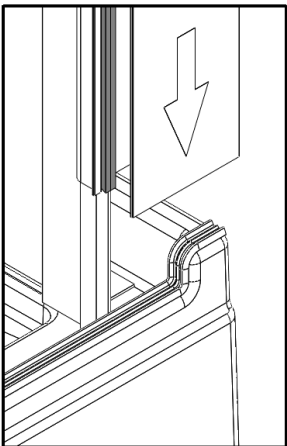
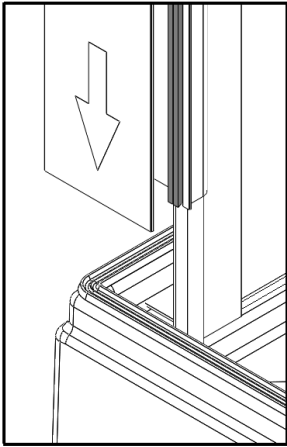
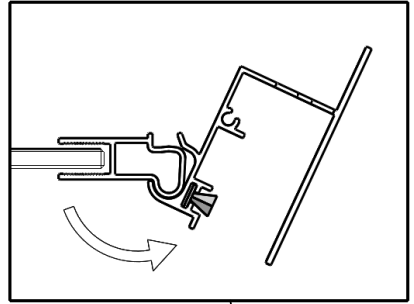
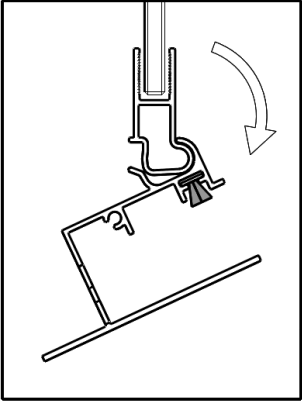

F Extérieur Ⓞ Outside
 E Exterior Ⓞ Esterno
 NL Buitenkant Ⓞ Außen

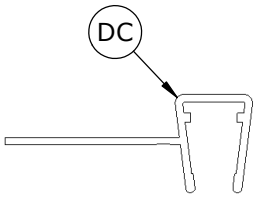

F Intérieur Ⓞ Inside
 E Interior Ⓞ Interno
 NL Binnenkant Ⓞ Innen

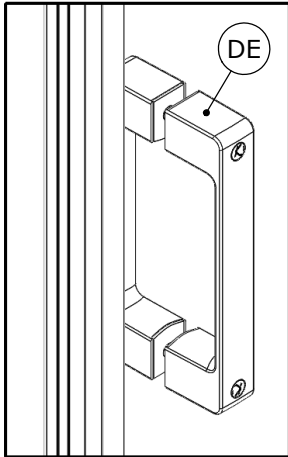
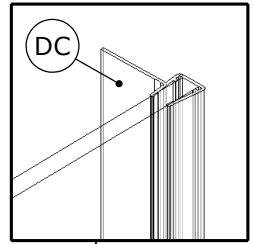

- F Voir notice concernée
- Ⓞ See installation instructions required
- E Ver manual adecuado
- L Vedere manuale appropriato
- NL Zie montage-instructies
- Ⓞ Siehe betreffende Anleitung

F Extérieur Ⓞ Outside
 E Exterior Ⓞ Esterno
 NL Buitenkant Ⓞ Außen

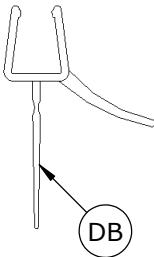

F Intérieur Ⓞ Inside
 E Interior Ⓞ Interno
 NL Binnenkant Ⓞ Innen

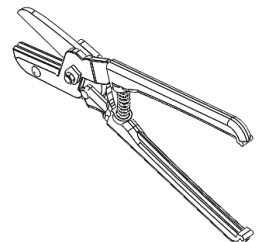
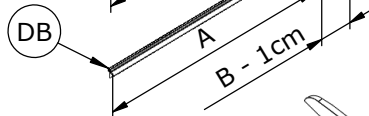

- Ajuster (DD) ● Adjust (DD) ● Ajustar (DD)
- Regolare (DD) ● Aanpassen (DD) ● Ausrichten (DD)

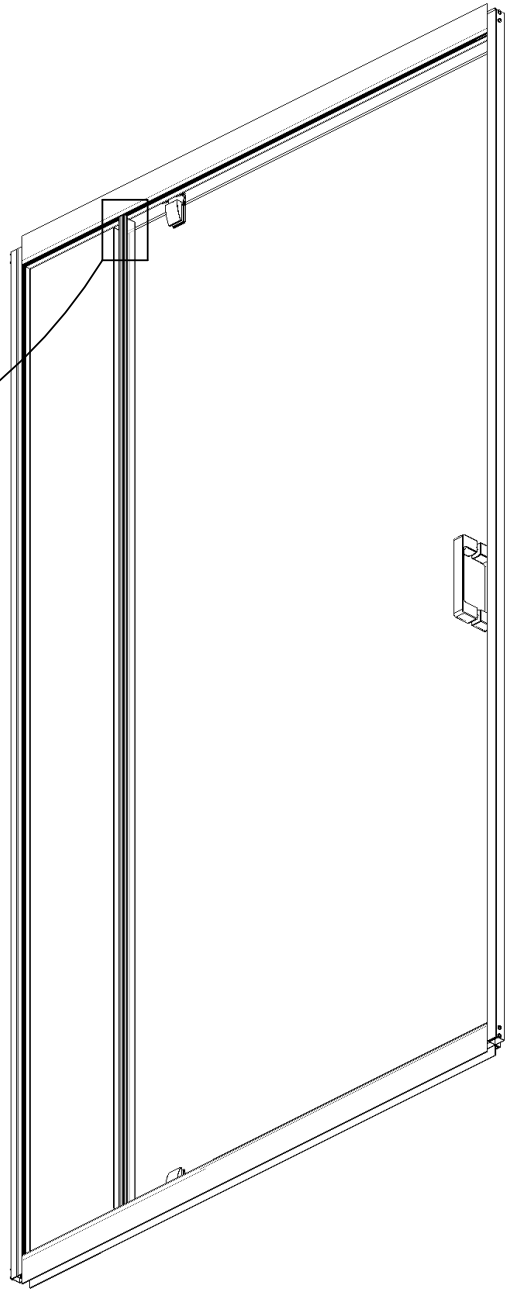
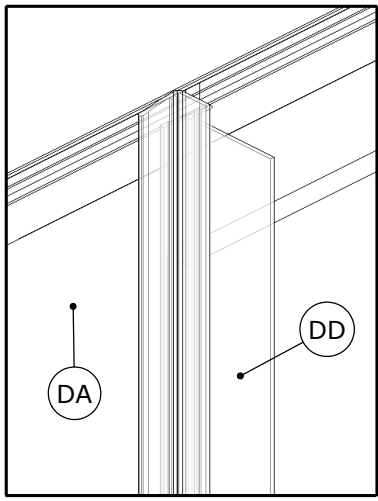
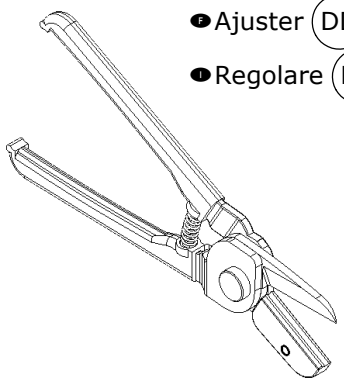

- Extérieur ● Outside ● Exterior
- Esterno ● Buitenkant ● Außen

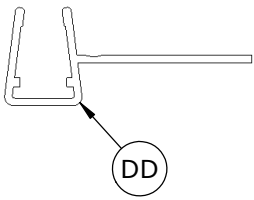

- Intérieur ● Inside ● Interior
- Interno ● Binnenkant ● Innen

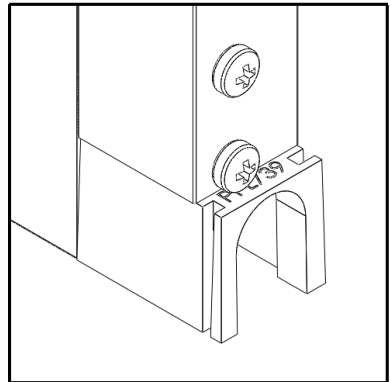
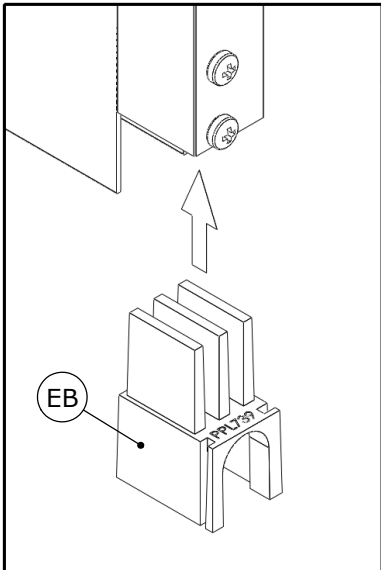
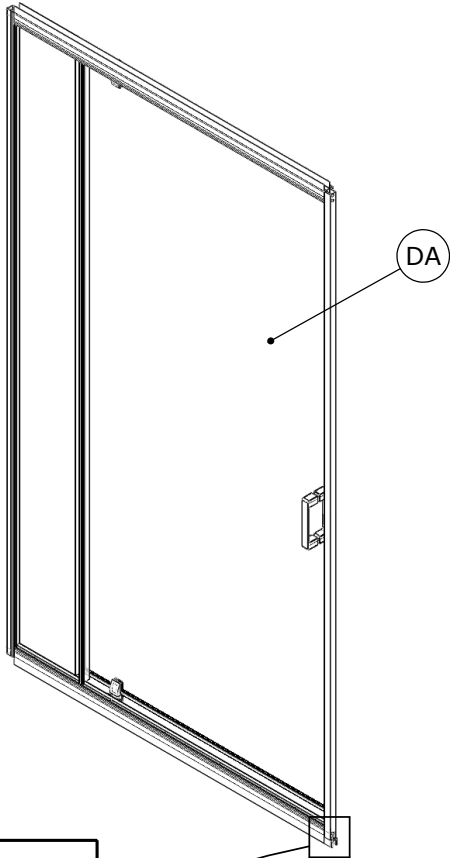

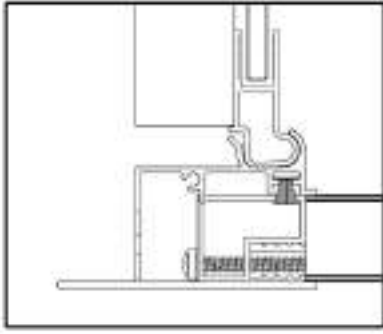
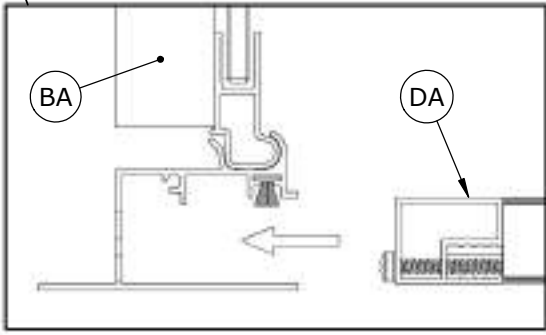
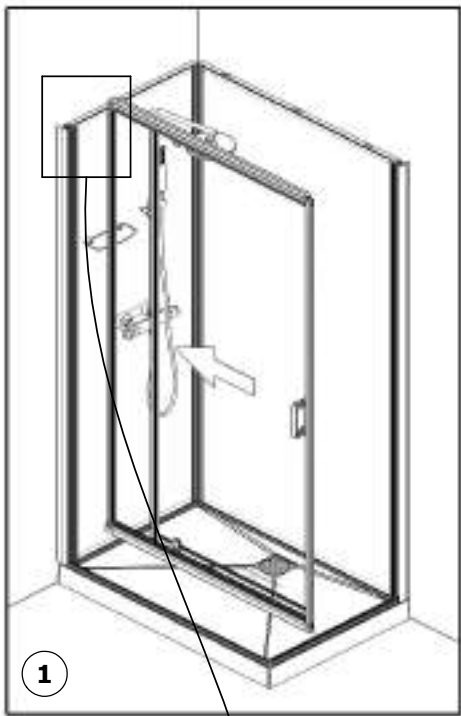

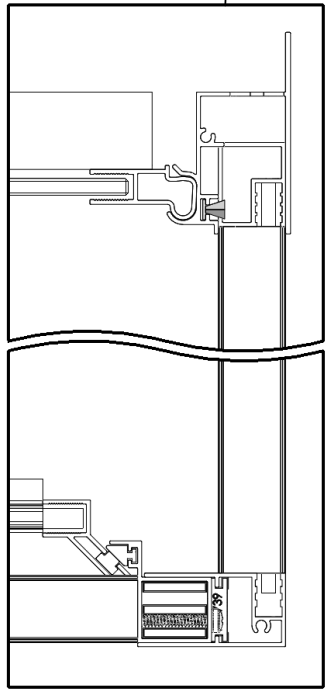
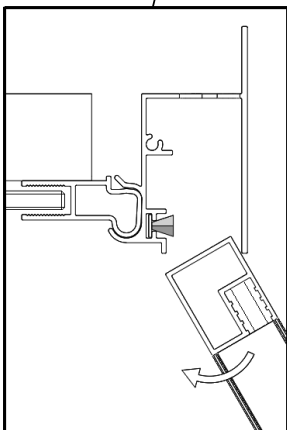
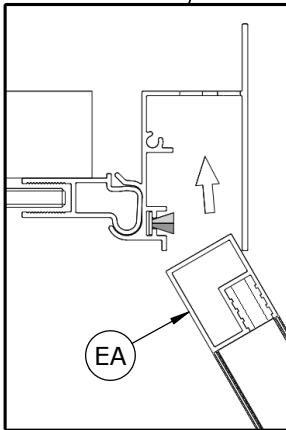
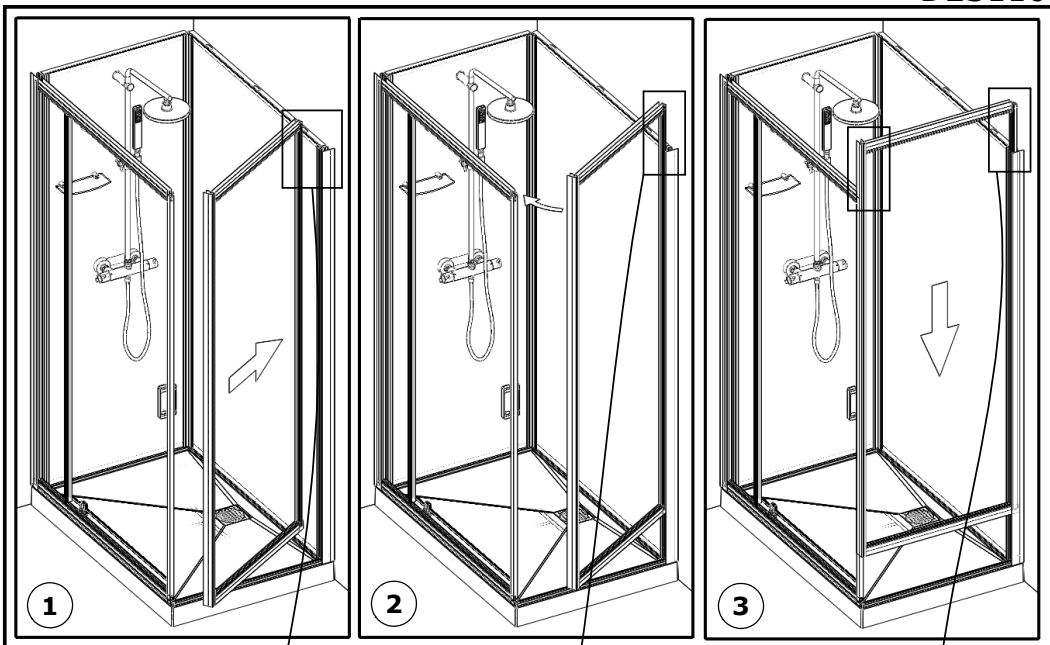

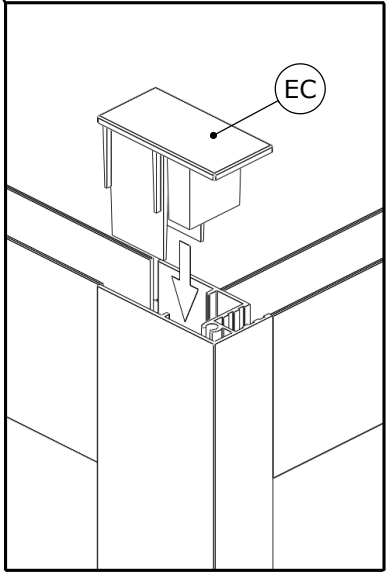
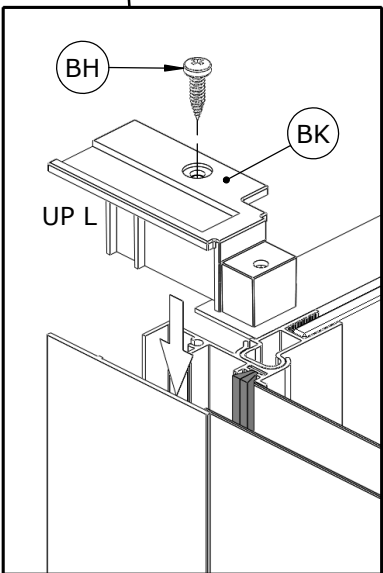
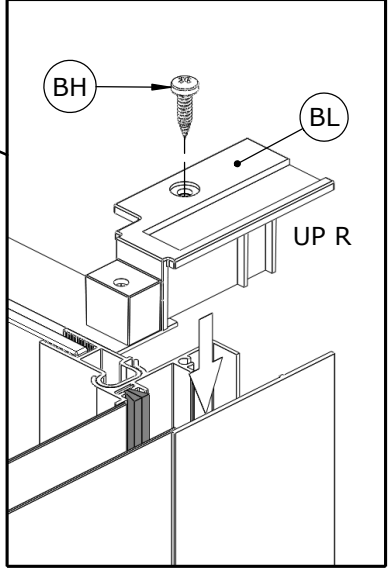
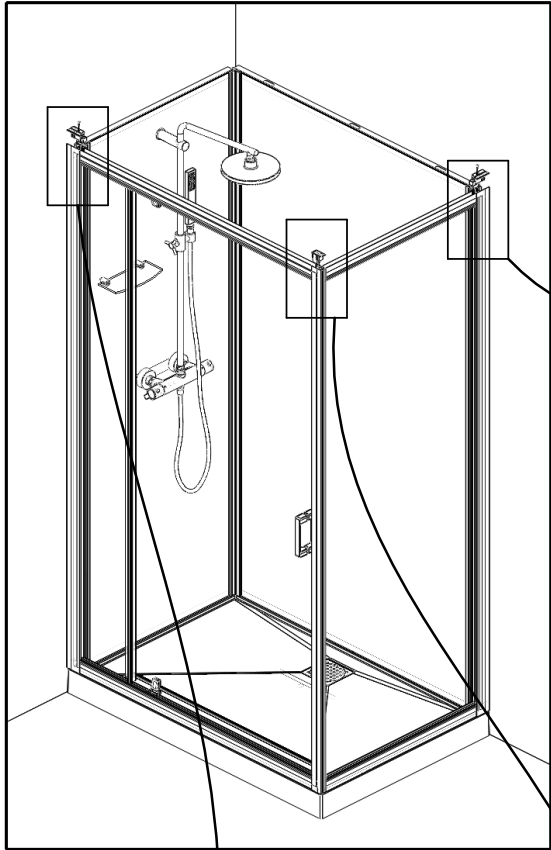

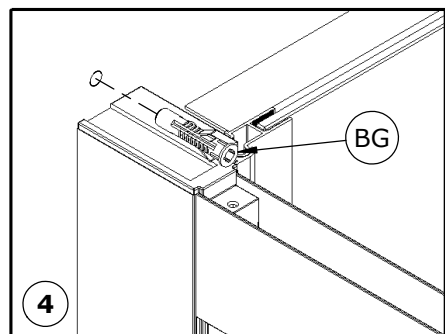
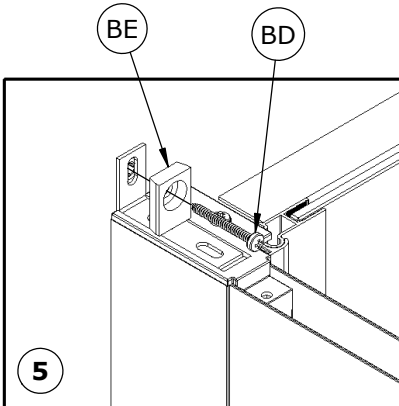
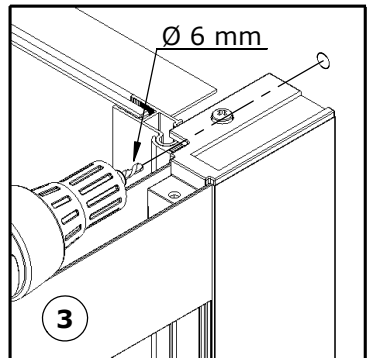
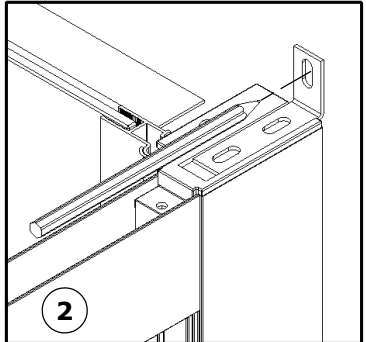
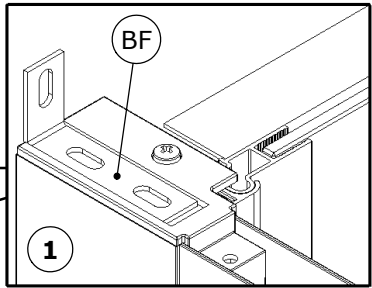
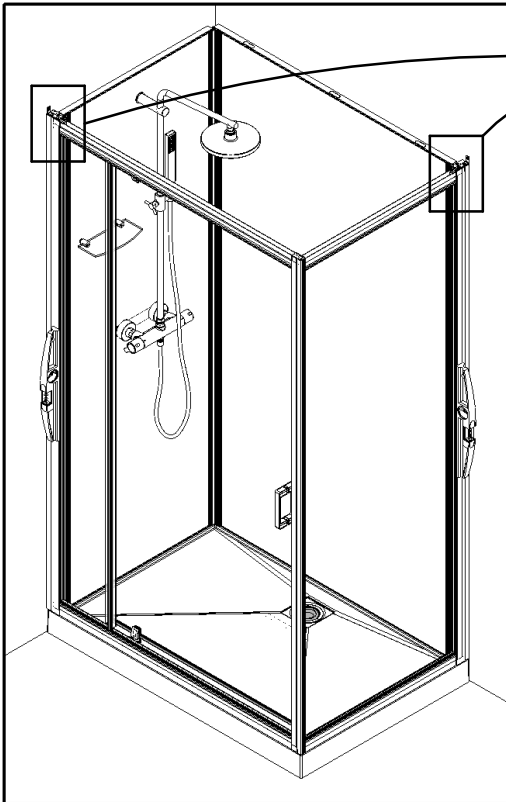

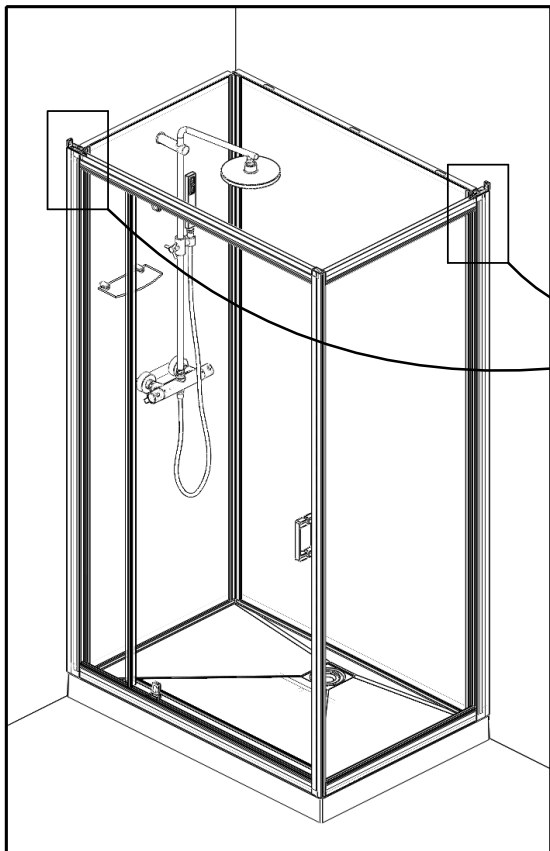

1

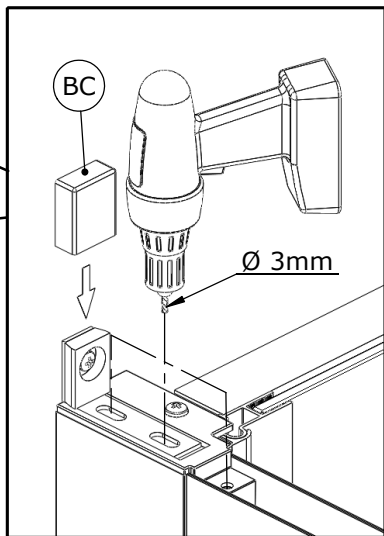

2

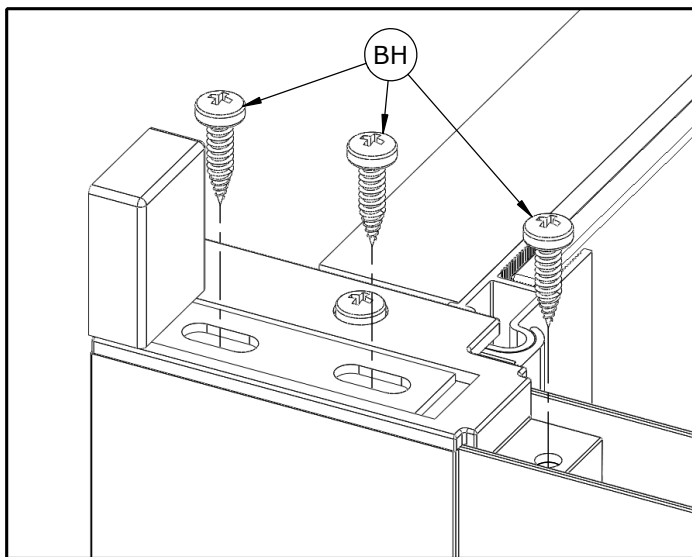

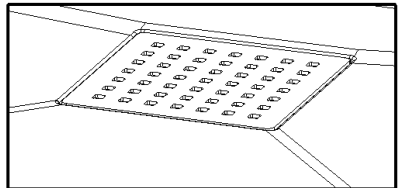
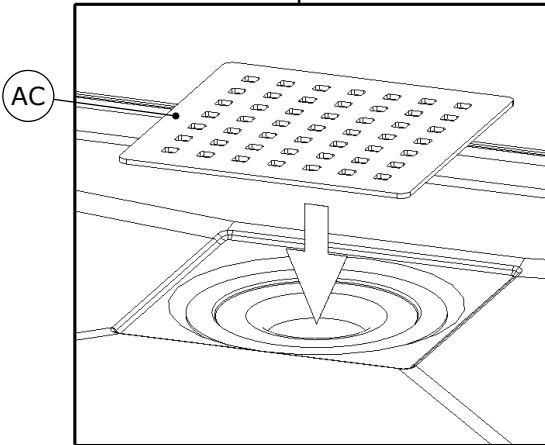
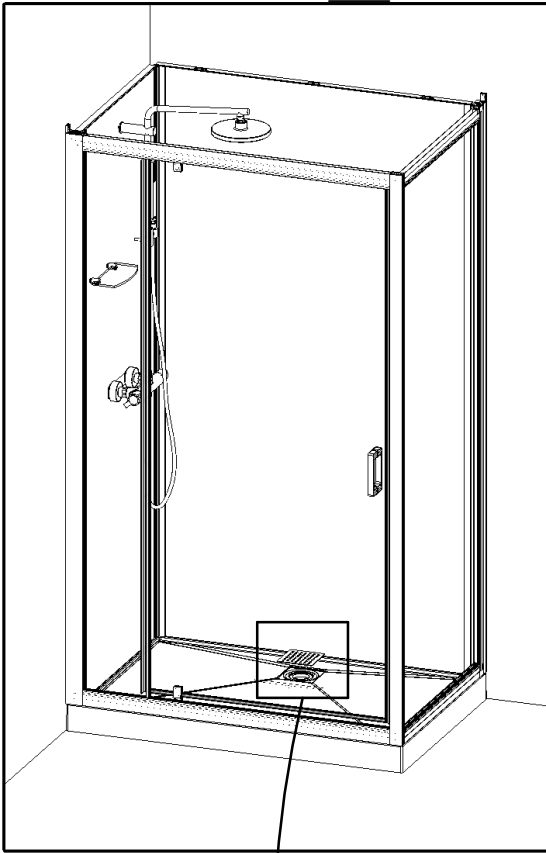

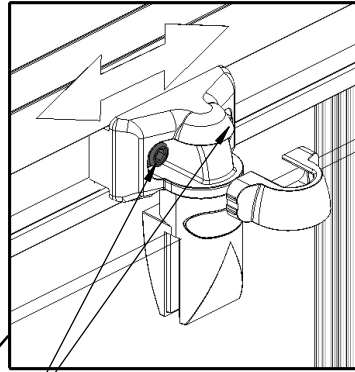

- Si nécessaire, desserrer, ajuster puis resserrer
- If necessary, untighten, adjust then tighten.
- Si es necesario, aflojen, ajuste y apriete.
- Se necessário, svitare, regolare quindi stringere.
- Indien nodig, en los, passen draai.
- Bei Bedarf, lösen, anpassen dann anziehen.

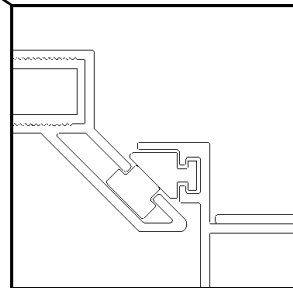
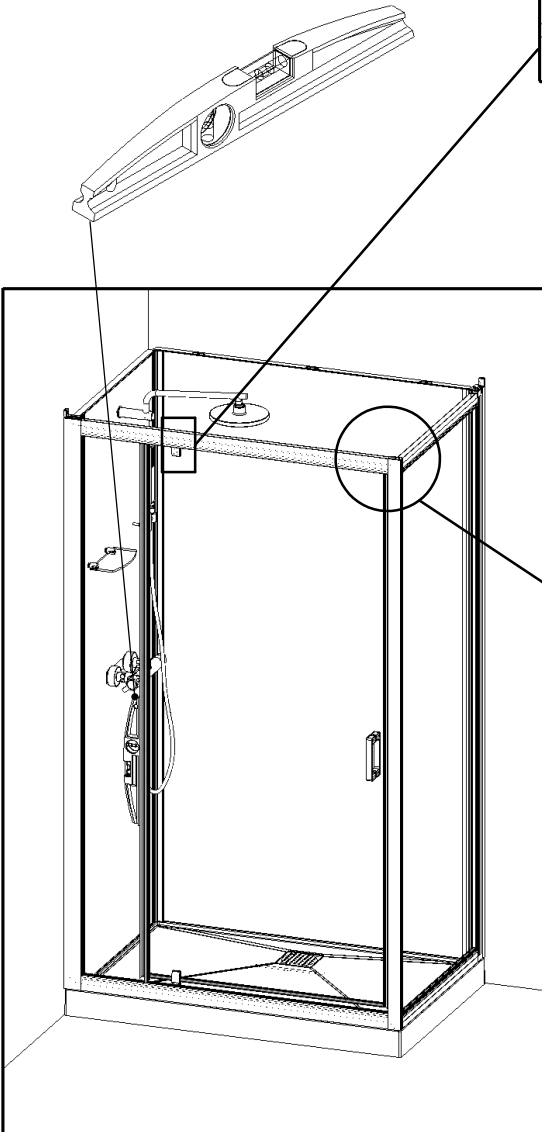



SAV
SERVICE HELPLINES
ASSISTENZA POST- VENDITA
SERVICIO POSTVENTA

FRANCE

02 40 21 29 45

UK

020 8842 0033

IRELAND

04697 33102

DEUTSCHLAND

+49 (0) 6074 / 30928 0

ITALIA

(0382) 6181

ÖSTEREICH

+43 1 710 60 70

SCHWEIZ

(01) 748 17 44

ESPANA

93 544 60 76

NEDERLAND

+31 475 487 100

BELGIË

+31 475 487 100

BELGIQUE

+31 475 487 100

РОССИЯ

963 19 40, 773 67 22

PORTUGAL

219 112 785