

PRODUCT DATA SHEET

Round Handle - 2 Outlet Concealed Valve with Diverter

Product Code: CONCEALED009

Product Name	CONCEALED009
Product Description	Round concealed shower valve bath filler
Product Transportation	
Barcode	5060500645847
Country of origin	CH
Commodity code	8481804090
Product Measurements	
Product Weight (KG)	3.375
Product Width (mm)	272
Product Height (mm)	90
Product Depth (mm)	165
Product Length (mm)	0
Primary Packed Measurements	
Packaged Weight	3.55
Packed Length	35
Packed Width	14
Packed Height	9
Packaging Weights	
Card (kg)	0.203
Paper (kg)	0
Wood (kg)	0
Plastic (kg)	0
Compliance DOP	HBDOC042 , HBDOC043

General Information	
Construction Material	Brass / Stainless Steel
Installation type	In Wall
Colour / Finish	Brass / Chrome
Tap / Shower Attributes	
WRAS Approved	Yes
TMV Approved	No
Minimum Operating Pressure (bar)	0.2
Maximum Operating Pressure (bar)	5
Flexible Tails Included	No
Number of tap holes required	N/a
Handle Type	Round
Swivel Spout	N/a
Inlet Connection	3/4 BSP
Outlet Connection	1/2 BSP
Tap Hole Diameter (mm)	N/a
Tap Type description	In wall Thermostatic mixer
Includes Waste	N/a
Valve / Cartridge Type	Thermostatic & Quarter Turn Cartridge
Cartridge Spare code	H102V
Flow Rates	
0.2bar (l/min)	6.5
0.5bar (l/min)	9.7
1bar (l/min)	14
2bar (l/min)	20.5
3bar (l/min)	27



SCUDO
BEAUTIFUL BATHROOMS

0330 124 7290

sales@scudo.co.uk - www.scudo.co.uk

Scudo is the trading name of Harrison Bathrooms Ltd. Whilst we endeavour to ensure that the product information is accurate we accept no liability for any information given. All images are for illustration purposes only. Product images and specification are subject to change. Measurements are in millimetres and are nominal.

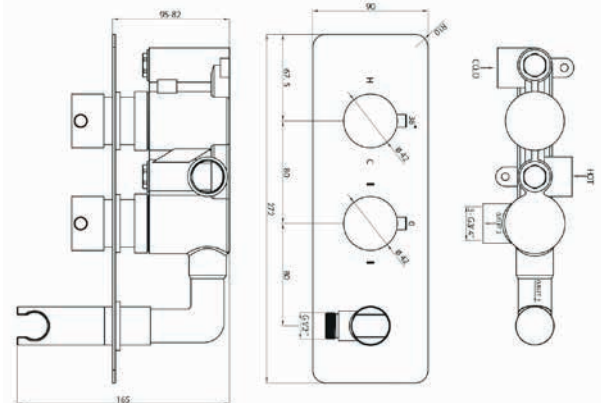

Dimensions

(measurements in mm)



LIFETIME GUARANTEE

We are confident in our products and we want our customer to be, we proudly give a lifetime guarantee on our taps and showers, further details can be found on our website

PRODUCT DATA SHEET

Product Code:



SCUDO
BEAUTIFUL BATHROOMS

0330 124 7290

sales@scudo.co.uk - www.scudo.co.uk

Scudo is the trading name of Harrison Bathrooms Ltd. Whilst we endeavour to ensure that the product information is accurate we accept no liability for any information given. All images are for illustration purposes only. Product images and specification are subject to change. Measurement are in millimetres and are nominal.

Showering - Specification

Anti-Scald	Yes
Shower Diverter function	Yes
Number of outlets	2
Thermostatic Temperature control	Yes
Cool Touch	No
Shower Handset functions	N/a
Minimum Working Pressure	0.2
Maximum Working Pressure	0
Shape	N/a
Pipe Centres (mm)	N/a
Inlet Connection	3/4 BSP
Outlet Connection	1/2 BSP
Adjustable	N/a
Adjustment (mm)	0
Handle Type	Round
Spares Codes	
Diverter Spares	No Spare
Thermostatic cartridge Spares	H102V

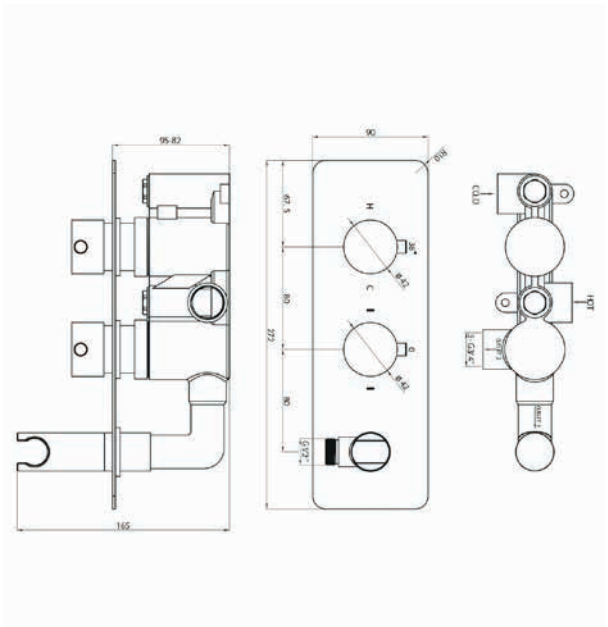

Dimensions
(measurements in mm)



LIFETIME GUARANTEE

We are confident in our products and we want our customer to be, we proudly give a lifetime guarantee on our taps and showers, further details can be found on our website