

PRODUCT DATA SHEET

Round Fixed Shower Head 300mm

Product Code: SH005L



SCUDO
BEAUTIFUL BATHROOMS

0330 124 7290

sales@scudo.co.uk - www.scudo.co.uk

Scudo is the trading name of Harrison Bathrooms Ltd. Whilst we endeavour to ensure that the product information is accurate we accept no liability for any information given. All images are for illustration purposes only. Product images and specification are subject to change. Measurement are in millimetres and are nominal.

Product Measurements

Product Weight:	0.88kg
Product Width:	300mm
Product Height:	48.5mm
Product Depth:	N/A
Product Length:	300mm

Product Transportation

Barcode:	5060500640521
Country of Origin:	China
Comodity Code:	7324900000

Primary Packed Measurements

Packaged Weight:	0.93kg
Packaged Length:	540mm
Packaged Width:	310mm
Packaged Height:	64mm

Packaging Weight

Card:	0.077kg
Plastic:	0.003kg

General Information

Construction Material:	Stainless Steel
Installation Type:	Arm Mounted
Colour / Finish:	Chrome

Shower Specification

Anti-Scald:	No
Shower Diverter Functions:	N/A
Number of Outlets:	1
Thermo Temp Control:	N/A
Cool Touch:	No
Shower Handset Functions:	1
Minimum Working Pressure:	0.5
Maximum Working Pressure:	5
Shape:	Round
Pipe Centre:	N/A
Inlet Connection:	1/2 BSP
Outlet Connection:	N/A
Adjustable:	Swivel
Adjustment:	N/A
Handle Type:	N/A

Flow Rates

0.2bar (l/min)	5
0.5bar (l/min)	10.2
1bar (l/min)	14.3
2bar (l/min)	19.9
3bar (l/min)	24.5

Compliance DOP

N/A

Spares

spares@harrisonbathrooms.com

Tap Attributes

Tap Type Description:	Drench
Includes Waste:	N/A
Valve / Cartridge Type:	N/A

For Part G Building regulations, compliance see flow regulator section of spec binder.

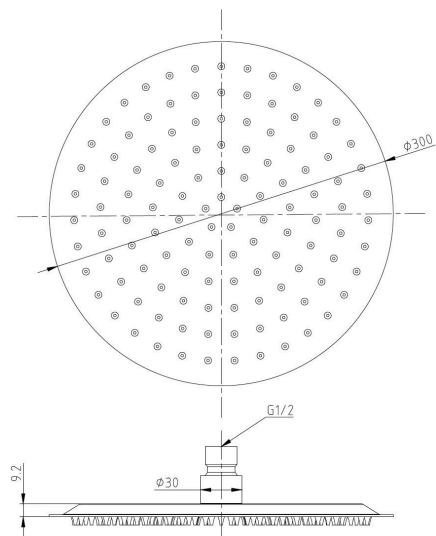

Dimensions (measurements in mm)



LIFETIME GUARANTEE

We are confident in our products and we want our customer to be, we proudly give a lifetime guarantee on our taps and showers, further details can be found on our website