

PRODUCT DATA SHEET

Onyx Freestanding Bath 1655x745mm

Product Code: BATH-DE1655

Product Measurements	
Product Weight:	44kg
Product Width:	750mm
Product Height:	580mm
Product Depth:	N/A
Product Length:	1655mm
Product Transportation	
Barcode:	5060766123233
Country of Origin:	China
Comodity Code:	8302500000
Primary Packed Measurements	
Packaged Weight:	52kg
Packaged Length:	1690mm
Packaged Width:	780mm
Packaged Height:	600mm
Packaging Weight	
Card:	8kg
Paper:	N/A
Wood:	N/A
Plastic:	0.4kg
General Information	
Construction Material:	Acrylic
Installation Type:	Freestanding
Colour/Finish:	White
Bath Attributes	
Bath Water Capacity (Litres):	205
Bath Water Capacity (m3):	0.205
Shape:	Oval
Handed:	Both
Bath Feet Included:	Yes
Supplied with Tap Holes:	No
Height Overflow/Soak Depth:	370mm
Internal Length Base:	1030mm
Internal Width/Depth Base:	410mm
Internal Height:	440mm
Supplied with Front Panel:	Included
Supplied with End Panel:	Included
Compatible Panel Part Code:	N/A
Compliance DOP	
HBDOC009 / HBDOC010	



SCUDO
BEAUTIFUL BATHROOMS

0330 124 7290

sales@scudo.co.uk - www.scudo.co.uk

Scudo is the trading name of Harrison Bathrooms Ltd. Whilst we endeavour to ensure that the product information is accurate we accept no liability for any information given. All images are for illustration purposes only. Product images and specification are subject to change. Measurement are in millimetres and are nominal.

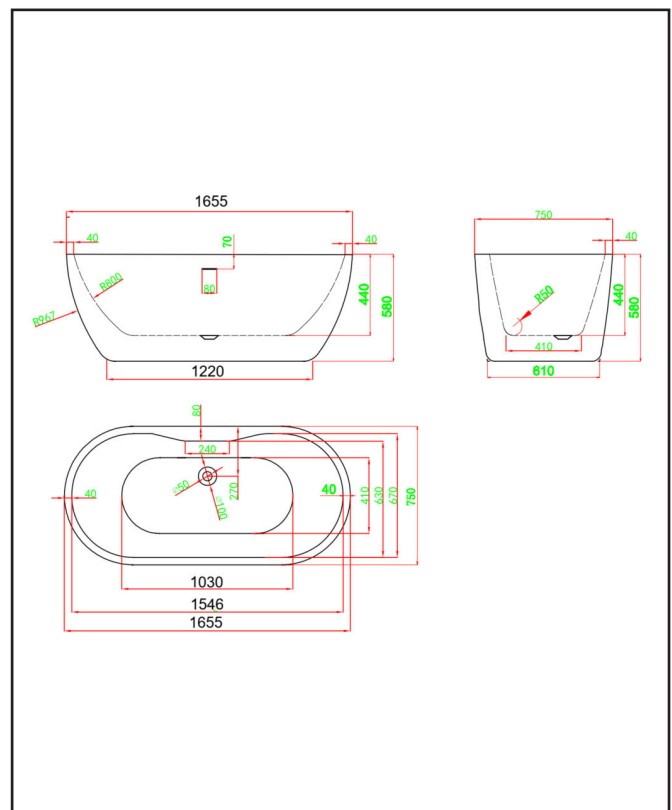
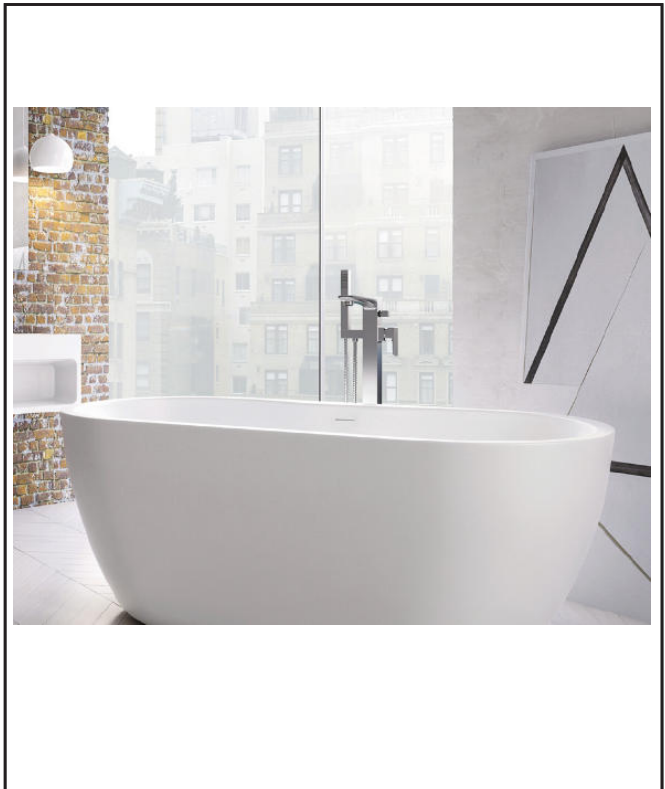

Dimensions
(measurements in mm)



LIFETIME GUARANTEE

We are confident in our products and we want our customer to be, we proudly give a lifetime guarantee on our taps and showers, further details can be found on our website