

# PRODUCT DATA SHEET

## Traditional Rigid Riser Shower with Fixed Head

Product Code: SHOWER005



**SCUDO**  
BEAUTIFUL BATHROOMS

0330 124 7290

sales@scudo.co.uk - www.scudo.co.uk

Scudo is the trading name of Harrison Bathrooms Ltd. Whilst we endeavour to ensure that the product information is accurate we accept no liability for any information given. All images are for illustration purposes only. Product images and specification are subject to change. Measurement are in millimetres and are nominal.

### Product Measurements

Product Weight:	6kg
Product Width:	138-158
Product Height:	1200
Product Depth:	355
Product Length:	N/A

### Product Transportation

Barcode:	5060766122052
Country of Origin:	China
Comodity Code:	8481801190

### Primary Packed Measurements

Packaged Weight:	7.05kg
Packaged Length:	1050
Packaged Width:	410
Packaged Height:	200

### Packaging Weight

Card:	1kg
Plastic:	0.05kg

### General Information

Construction Material:	Brass / Plastic / Stainless Steel
Installation Type:	Wall Mounted
Colour / Finish:	Chrome

### Shower Specification

Anti-Scald:	Yes
Shower Diverter Functions:	No
Number of Outlets:	1
Thermo Temp Control:	Yes
Cool Touch:	No
Shower Handset Functions:	N/A
Minimum Working Pressure:	0.5
Maximum Working Pressure:	5
Shape:	Cross Handle
Pipe Centre:	138-158mm
Inlet Connection:	15mm
Outlet Connection:	1/2 BSP
Adjustable:	No
Adjustment:	N/A
Handle Type:	N/A

### Flow Rates

0.2bar (l/min)	5.6
0.5bar (l/min)	8.8
1bar (l/min)	13.8
2bar (l/min)	20.8
3bar (l/min)	25.7

### Compliance DOP

N/A

### Spares

spares@harrisonbathrooms.com

### Tap Attributes

Tap Type Description:	Exposed Valve
Includes Waste:	N/A
Valve / Cartridge Type:	N/A

For Part G Building regulations, compliance see flow regulator section of spec binder.

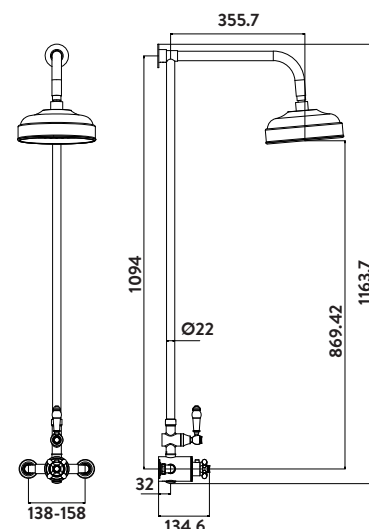

## Dimensions

(measurements in mm)



### LIFETIME GUARANTEE

We are confident in our products and we want our customer to be, we proudly give a lifetime guarantee on our taps and showers, further details can be found on our website