

# ST PUMP15TN

## Accessories

### 1.5 Bar Twin Ended Shower Pump Powered By Stuart Turner



### Specification

<b>Pump Type:</b>	Single speed twin impeller
<b>Power Supply:</b>	230 Volts AC
<b>Power Consumption:</b>	385 Watts
<b>Inlet Connection:</b>	Flexible hose - 15mm push fit
<b>Outlet Connection:</b>	Flexible hose - 15mm push fit
<b>Supply:</b>	Suitable for gravity fed systems only
<b>Max. Inlet Head:</b>	10 Meters
<b>Max. Head (closed valve):</b>	15 Metres
<b>Motor Rating:</b>	30 minutes on / 30 minutes off
<b>Max. Working Pressure:</b>	3.0 Bar
<b>Pump Rating:</b>	1.5 Bar / 32 LPM
<b>Max. Inlet Water Temperature:</b>	65°C

### Features:

- Twin impeller for boosting two water supplies.
- Fully automatic flow switch control - pump automatically starts when flow water exceeds 0.8 litres per minutes.
- Pump rated at 1.5 bar pressure equivalent to 15 meters head height
- Medium boost performance
- Low noise - fitted with anti-vibration feet
- Min. inlet water temperature - 4°C
- Max. inlet water temperature - 65°C
- Max. number of starts per hour - 60
- Max. ambient air temperature - 40°C

### Product Certifications:

For more products, visit our website:  
<http://www.bristan.com>

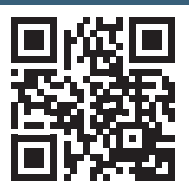

### Dimensions (measurements in mm)

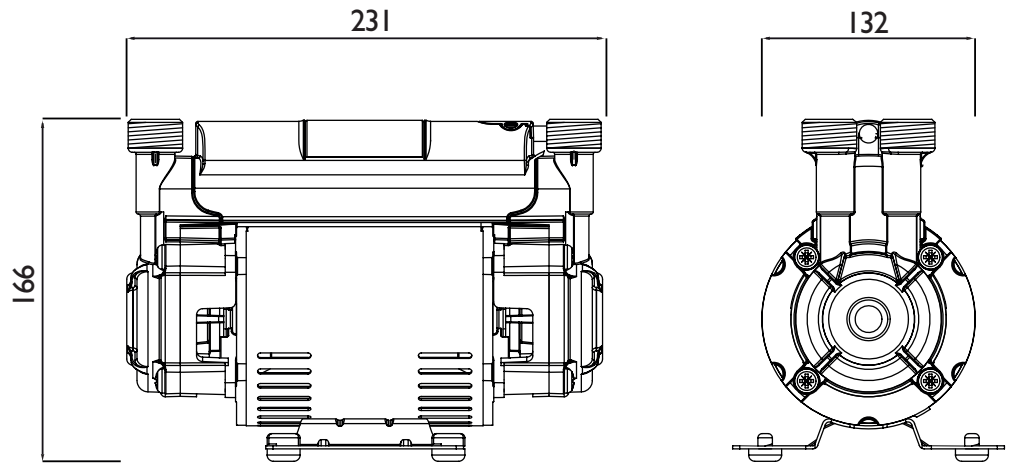

## TECHNICAL DATA SHEET



# BRISTAN

TAPS & SHOWERS D3